

ALMAlight
Barcelona

Catálogo general

General catalogue

2023

V03-23

ALMA light
Barcelona

Quién es

Josep Novell (Barcelona 1953)

Oriol Llahona (Barcelona 1977)

Ernest Perera (Barcelona 1974)

Jordi Llopis (Barcelona 1972)



Josep Novell.

Estudia Diseño de Producto en ELISAVA (Escuela Universitaria de Diseño e Ingeniería de Barcelona), y posteriormente se gradúa en Bachelor of Arts por la University of Southampton (Reino Unido). Desde 1980 se dedica al diseño, tanto desde su propio estudio como en colaboración con otros diseñadores. En 1984 funda la empresa "Via Design", junto con Joan Suñol, proyecto que finaliza en 1988. Posteriormente crea "Novell/Puig Design" junto con el diseñador Josep Puig. Además, desde 1984 imparte clases como profesor de proyectos en la Escuela Superior de Diseño ELISAVA. Es miembro de la Asociación de Diseño Industrial del Foment de les Arts i del Disseny (ADI-FAD). Para ALMA LIGHT, conjuntamente con los diseñadores Josep Puig y Ernest Perera, ha desarrollado luminarias clásicas de la marca, como las colecciones BLOW, FLAT, MOON, ORB, ROOM, STONE, SUN y TINY.

Josep Novell está particularmente interesado en relacionar estrechamente tres conceptos: forma, material y proceso de fabricación. Además tiene muy en cuenta aspectos más intangibles del producto como la comunicación, la emoción o la ética. Sus diseños están presentes en ámbitos tan diferentes como la iluminación, el packaging, el diseño de producto, el mobiliario o la imagen corporativa. Josep Novell es uno de los grandes diseñadores de nuestro país, y muchas de sus creaciones han sido galardonadas y expuestas en ferias y certámenes de diseño en Europa, Estados Unidos y Asia.

Oriol Llahona.

Estudia Diseño Industrial en, Barcelona, Alemania y Reino Unido. Se gradúa en

1999 y obtiene su postgrado en 2004. Después de trabajar en diversas empresas y estudios de diseño, en 2004 crea su propio proyecto llamado "Llahona Design Studio" en el cual desarrolla su visión cosmopolita, contemporánea y positiva del diseño, la búsqueda de la esencia y las emociones en nuestra vida. En 2012 es llamado a unirse a Philips, diseñando luminarias de origen y asumiendo su Dirección Creativa. Actualmente trabaja en varios proyectos en Europa, América y Asia que incluyen diseños de iluminación, muebles y electrónica de consumo. Para ALMA LIGHT ha desarrollado luminarias que ya se han convertido en clásicos, como las colecciones BATH, BIG BROTHER, CAPITONÉ, MADAME, NOTE, PROFILE, SPIKE y SUIT.

Oriol Llahona es un diseñador nato, curioso y de mente abierta, su estilo es una mezcla de búsqueda de nuevos materiales y tecnologías con un sereno y refinado sentido de las formas. Sus diseños abarcan ámbitos tan diversos como la iluminación, el packaging, el diseño de producto, los espacios de restauración, el mobiliario. Muchas de sus creaciones han sido expuestas en salones de Italia, Alemania y Japón y han sido seleccionadas para diversas publicaciones sobre diseño internacional.

Ernest Perera.

Ernest Perera combina sus estudios de escultura en la Facultad de Bellas Artes de la Universidad de Barcelona con los de Diseño Industrial en la Escuela ELISAVA (Escuela Universitaria de Diseño e Ingeniería) de la misma

ciudad.

Funda su propio estudio en 1999, donde diseña productos y experiencias para ayudar a las empresas a ser más competitivas, desde piezas únicas a elementos altamente seriados. Sus trabajos se caracterizan por proporcionar conceptos renovados en cada proyecto, aportando soluciones específicas para cada caso. En 2006 crea "Amor de Madre", su propia empresa editora de productos para el hogar, la cual le permite imprimir su libertad de creación y de experimentación en diversos productos del ámbito del hogar. Desde 1998 es docente en varias universidades de diseño de Barcelona. Actualmente es el Jefe de Área de Diseño de Productos en la escuela LCI Barcelona.

Ha colaborado con empresas como Camper, Lékué, Delica, Mago Urban, Alma Light –donde desarrolla junto a Josep Novell las colecciones BLOW, FLAT, MOON, ORB, PILL y SQUARE--, Museo Picasso de Barcelona, Rumitag, Artesanía de Cataluña o el ADI-FAD. Ha recibido diversos galardones, como una selección a los Premios DELTA de Diseño ADI-FAD, Barcelona (2009) y el primer premio en el certamen internacional Les Découvertes, Maison Objet, París (2008).

Sus creaciones han sido expuestas en galerías de todo el mundo y han sido seleccionadas para diversas publicaciones sobre diseño internacional.

Jordi Llopis.

Se forma como diseñador en la Escuela ELISAVA de Barcelona y en el "Royal College of Art" de Londres.

Diseñador Industrial, ha trabajado como Design Manager en empresas de iluminación, llevando a cabo la dirección de nuevos productos e identidad corporativa. Lleva años colaborando con empresas de iluminación, mobiliario urbano y objetos para el hogar. "Lifelight", lámpara creada por él en 2003, forma parte de la colección permanente del "Museu del Disseny" de Barcelona, y su lámpara "Clipa'm" fue seleccionada en los Premios Delta 2016.

Actualmente dirige su propio estudio de diseño llamado Jordi Llopis Design, en Barcelona, y es co-fundador de la editora Brots. Trabaja desarrollando nuevos diseños para el mundo de la iluminación y elementos urbanos, así como diseñando y produciendo sus nuevas colecciones para Brots. La excusa es diseñar para uno mismo como autoencargo, sin premisas ni filtros previos, para poder llegar a un producto muy personal, original y coherente que ofrecer. Esta es parte de la filosofía que se quiere transmitir en Brots. Jordi Llopis colabora, además, como profesor externo en ESDI, Escuela Superior de Diseño de Barcelona y ELISAVA Alumni y es tutor en el Máster de ESdesign Barcelona. Ha sido jurado en los Premios Eil de ELISAVA de Barcelona, y ha impartido talleres en la Universidad de Aguascalientes en México y en ELISAVA.

Who is

Jordi Llopis (Barcelona 1972) Ernest Perera (Barcelona 1974) Oriol Llahona (Barcelona 1977) Josep Novell (Barcelona 1953)

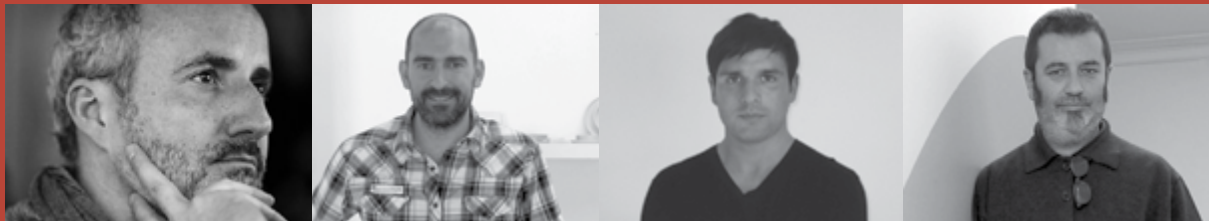

Ernest Perera.

He combined his studies of sculpture in the Faculty of Fine Arts of the University of Barcelona with those of Industrial Design in ELISAVA (University School of Design and Engineering) of the same city. He founded his own studio in 1999, where he designed products and experiences to help companies become more competitive, from unique pieces to highly serialized elements. His works are characterized by providing renewed concepts in each project, bringing specific solutions for each case. In 2006, he created "Amor de Madre", his own company for home products, which allows him to develop his freedom of creation and experimentation on various household products. Since 1998 he has been teaching at several design universities in Barcelona. He is currently the Head of Product Design at LCI Barcelona School. He has collaborated with companies such as Camper, Lékué, Delica, Mago Urban, ALMA LIGHT - where he developed, together with Josep Novell, the collections BLOW, FLAT, MOON, ORB, PILL and SQUARE--, Barcelona Picasso Museum, RumiTag, Artesanía de Cataluña or the ADI-FAD. He has received several awards, such as a selection at the DELTA Design Awards ADI-FAD, Barcelona (2009) and the first prize at the international competition Les Découvertes, Maison Objet, Paris (2008). His creations have been exhibited in galleries around the world and have been selected for various publications on international design.

Jordi Llopis

was formed as a designer at the ELISAVA School in Barcelona and at the 'Royal College of Art' in London. Industrial Designer, he has worked as a Design Manager in lighting companies carrying out the direction of new products and corporate identity. He has been collaborating with lighting companies, street furniture and household items for years. 'Lifelight', a lamp created by him in 2003, is part of the permanent collection of the 'Museu del Disseny' of Barcelona, and the 'Clipa'm' lamp was selected in the Delta 2016 Awards. He currently directs his own design studio called Jordi Llopis Design, in Barcelona, and is co-founder of the editing company Brots. He works developing new designs in the world of lighting and urban elements, as well as designing and producing new collections for Brots. The excuse is to design for oneself on self-request, without prejudices or previous filters, in order to arrive at a very personal, original and coherent product to offer. This is part of the philosophy that to be transmitted by Brots. Jordi Llopis also collaborates as an external teacher at ESDI, Barcelona School of Design and ELISAVA Alumni and is Tutor in the ESdesign Barcelona Master. He has been a jury at the Ei Awards! of ELISAVA in Barcelona, and has collaborated in workshops at the University of Aguascalientes in Mexico and in ELISAVA.

Oriol Llahona.

He studied Industrial Design in Barcelona, Germany and the United Kingdom. He graduated in 1999 and obtained his postgraduate degree in 2004. After working in various companies and design studios, in 2004 he created his own project called "Llahona Design Studio" in which he developed his cosmopolitan, contemporary and positive vision of design, the pursuit of essence and emotions in our life. In 2012 he was called to join Philips, designing light fixtures and undertaking his Creative Direction. He is currently working on several projects in Europe, America and Asia including lighting designs, furniture and consumer electronics. For ALMA LIGHT has developed luminaires that have already become classics, such as BATH, BIG BROTHER, CAPITONÉ, MADAME, NOTE, PROFILE, SPIKE and SUIT. Oriol Llahona is a born designer, curious and open-minded, his style is a mixture of searching for new materials and technologies with a serene and refined sense of forms. His designs cover areas as diverse as lighting, packaging, product design, dining spaces, furniture. Many of his creations have been exhibited in salons in Italy, Germany and Japan. They have also been selected for various publications on international design

Josep Novell.

He studied Product Design at ELISAVA (School of Design and Engineering of Barcelona) and he later graduated as Bachelor of Arts at the University of Southampton (United Kingdom). Since 1980 he has been dedicated to design, both from his own studio and in collaboration with other designers. In 1984 he founded the company "Via Design, SA" together with Joan Suñol, a project that ended in 1988. He later created "Novell / Puig Design" together with the designer Josep Puig. In addition, since 1984 teaches as a professor of projects in the School of Design ELISAVA. He is a member of the Industrial Design Association of the Foment de les Arts i del Disseny (ADI-FAD). In ALMA LIGHT, together with the designers Josep Puig and Ernest Perera, he has developed classic luminaires of the brand such as the collections BLOW, FLAT, MOON, ORB, ROOM, STONE, SUN and TINY. Josep Novell is particularly interested in closely relating three concepts: form, material and manufacturing process. He also takes into account more intangible aspects of the product such as communication, emotion or ethics. His designs are present in areas as different as lighting, packaging, product design, furniture or corporate image. Josep Novell is one of the great designers of our country, and many of his creations have been awarded and exhibited in fairs and design contests in Europe, the United States and Asia.

Ilumínate

Obj (Barcelona 2007)

Josep Puig (Barcelona 1959)

Cristian Cubiñá (Barcelona 1968)

Alfonso de la Fuente (Valladolid 1974)

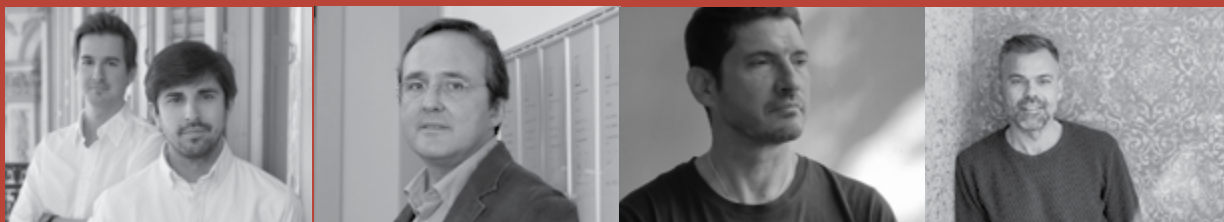

Obj (Javier Taberner & Nacho Poveda)

Nace en 2007 de la unión de sus dos socios: Javier Taberner y Nacho Poveda. Sus diseños de mobiliario, producto e iluminación han sido reconocidos con numerosos premios y distinciones, habiendo sido difundidos en publicaciones especializadas a nivel internacional. El estudio también ha participado en distintas exposiciones y eventos en diferentes ciudades de Iberoamérica, Londres, Madrid, Milán, Barcelona, Saint Étienne, etc.

Josep Puig

Estudia Diseño Industrial en ELISAVA (Escuela Universitaria de Barcelona Diseño e Ingeniería) y obtiene el título en 1980. Posteriormente amplía su formación en la University of Southampton (Reino Unido) donde se gradúa con honores como Bachelor of Arts. Es miembro de la Asociación de Diseño Industrial del Fomento de las Artes y el Diseño ADI-FAD y ha formado parte de la Junta de la Asociación en diversas ocasiones. Ha impartido cursos y talleres en numerosos foros de diseño y actualmente es profesor en la Escuela Superior de Diseño ELISAVA, donde dirige el Máster en Diseño y Desarrollo de Producto en ELISAVA desde 2006. Josep Puig es un diseñador inquieto y brillante cuya creatividad se ha desarrollado en multitud de ámbitos. Entre otras muchas iniciativas, es miembro fundador del grupo de diseño experimental "Transatlàntic" junto a Ramón Benedito y Lluís Morillas. En 1989 se embarca en el proyecto "The Barna Crossing in Fukuoka" con Alfredo Arribas Arquitectos Asociados, para el diseño de una colección de objetos para un complejo multimedia en Fukuoka (Japón). Durante su trayectoria profesional

ha recibido numerosos premios y distinciones de organismos españoles e internacionales. Junto al diseñador Josep Novell funda en 1992 el estudio "Novell/Puig Design", orientado al diseño y desarrollo de productos. En 2010 crea su propio estudio "Puig[i]Cabeza Design". Para ALMA LIGHT ha desarrollado, junto con Josep Novell, colecciones de luminarias ya clásicas de la marca como STONE, SUN y TINY. Sus diseños, numerosos de ellos premiados en certámenes nacionales e internacionales, abarcan áreas tan variadas como los artículos sanitarios, gafas, packaging, cerámica y vidrio, electrodomésticos, mobiliario, iluminación y menaje del hogar.

Cristian Cubiñá

Estudia Diseño Industrial en la Escuela ELISAVA (Escuela Universitaria de Diseño e Ingeniería) de Barcelona y una vez finaliza su formación decide crear su proyecto empresarial, fundando la sociedad familiar "Hustadt Iluminación". Durante los primeros años asume las responsabilidades de Jefe de Producto. En 2003, momento en que la compañía crea la marca ALMA LIGHT, se responsabiliza de áreas más amplias como diseño de producto, selección de proveedores de proximidad y control de la fabricación y de sus estándares de máxima calidad, siempre con la vista puesta en la continua evolución del mercado, tanto en términos de diseño como en aspectos puramente tecnológicos y productivos. Es en el proyecto ALMA LIGHT donde Cristian Cubiñá puede desarrollar sus dotes de diseñador, proyectando los stands de las ferias a las que la empresa acude como expositora, y creando colecciones ya clásicas como la DROP o la LENS. Más adelante firmará otras

creaciones, como las familias CANDLE, CAPSULE, DECO, HOTEL, KONE, LED BOX, LED OVAL, LED POLE, THE LIGHT y THE PALM. Sus diseños están impregnados de su carácter curioso y observador y en su afán por fijarse en todo lo que ve a su alrededor, donde cualquier detalle puede ser susceptible de convertirse en una luminaria.

Cristian Cubiñá es uno de los diseñadores más reputados en el campo de la iluminación decorativa contemporánea, sector en el cual está especializado. Sus creaciones han sido expuestas en diversas ferias europeas y han sido seleccionadas para diversas publicaciones sobre diseño internacional.

Alfonso de la Fuente (Pichiglas Studio)

Afincado en Barcelona desde 1997, Alfonso de la Fuente ha ido evolucionando como artista autodidacta, aportando aires de renovación al panorama del diseño en el ámbito de la decoración a base de trabajo, talento, pasión e imaginación. Después de que su llegada a Barcelona le descubriese el reciclaje del plástico, Pichiglas empieza a reutilizar botellas de consumo masivo para crear objetos, creando su primer aparato de iluminación decorativa en 1997. Pichiglas se desarrolla entonces a gran velocidad gracias a la continua creatividad, a la pasión y al trabajo, produciendo siempre con humor, ironía y color, y convirtiéndose en participe de esa Barcelona tan de moda de los primeros años del siglo XXI en la que todo era posible. Después de cosechar un notable éxito con su línea de objetos decorativos y accesorios, el diseñador decide incluir en sus intereses el interiorismo integral para la decoración de bares de moda, restaurantes, comercios, locales y clubs, algunos convertidos ya en grandes clásicos como la discoteca barcelonesa FONFONE. El trabajo de Pichiglas Studio se da a conocer ya no sólo a nivel nacional, sino que empieza a recibir encargos de países como Francia e Italia. Lo que diferencia a Pichiglas Studio del resto de diseñadores es, precisamente, su capacidad para hacer de las texturas, los materiales y los objetos cotidianos verdaderas combinaciones de efectos visuales que no dejan a nadie indiferente. En una época en la que triunfa el minimalismo, Alfonso de la Fuente y Pichiglas Studio, revolucionan la decoración de los espacios con un denominador común: explosión de color combinada con una sorprendente simplicidad conceptual que consiguen un resultado de alto poder expresivo. En palabras del propio diseñador, "Hoy en día, tenemos que contar cosas cuando creamos, sorprender y chocar, pero sin perder nuestra esencia, aquello que nos define"

Light up

Alfonso de la Fuente (Valladolid 1974) Cristian Cubiñá (Barcelona 1968)

Josep Puig (Barcelona 1959)

Obj (Barcelona 2007)



DROP or LENS. Later, he signs other creations such as CANDLE, CAPSULE, DECO, HOTEL, KONE, LED BOX, OVAL LED, LED POLE, THE LIGHT and THE PALM. His designs are imbued with his curious and observant character and his eagerness to look at everything he sees around him, where any detail can be susceptible of becoming a light fitting.

Cristian Cubina is one of the most renowned designers in the field of contemporary decorative lighting, a sector in which he is specialized. His creations have been exhibited at various European fairs and have been selected for several publications on international design.

Alfonso de la Fuente (Pichiglas Studio)

Based in Barcelona since 1997, Alfonso de la Fuente has evolved as a self-taught artist, bringing renewal airs to the design environment in the field of decoration based on work, talent, passion and imagination.

After his arrival in Barcelona, when finding out more about the recycling of plastic, Pichiglas begins to reuse bottles of mass consumption to create objects, designing his first decorative lighting fixture in 1997. Pichiglas develops then at high speed thanks to his continuous creativity, passion and work, always producing with humor, irony and color, and becoming a participant in that fashionable Barcelona of the first years of the 21st century in which everything was possible.

After reaping a remarkable success with his line of decorative objects and accessories, the designer decides to include in his interests the integral interior design for the decoration of trendy bars, restaurants, shops, stores and clubs, some of which have already become great classics such as the Barcelona disco FONFONE. The work of Pichiglas Studio is already known not only nationally, but begins to receive orders from countries such as France and Italy. What sets Pichiglas Studio apart from other designers is precisely its ability to make textures, materials and everyday objects true combinations of visual effects that leave no one indifferent. In an era in which minimalism triumphs, Alfonso de la Fuente and Pichiglas Studio revolutionize the decoration of spaces with a common denominator: explosion of color combined with a surprising conceptual simplicity that achieve a result of high expressive power.

In the words of the designer himself: "Today, we have to tell things when we create, we must surprise and collide, but without losing our essence, what defines us."

Japan. During his professional career he has received numerous awards and distinctions from Spanish and international organizations. Together with the designer Josep Novell founded in 1992 the study "Novell / Puig Design", oriented to the design and development of products. In 2010 he created his own studio "Puig [i] Cabeza Design". For ALMA LIGHT has developed, along with Josep Novell, collections of classic luminaires of the brand as STONE, SUN and TINY. Its designs, many of them awarded in national and international competitions, cover areas as varied as sanitary ware, glasses, packaging, ceramics and glass, household appliances, furniture, lighting and household items.

Cristian Cubiñá.

He studies Industrial Design at the ELISAVA School (University School of Design and Engineering) in Barcelona and, once he finishes his training, he decides to create his own business project, founding the family society "Hustadt Iluminación".

During the first years he undertakes the responsibilities of Product Manager.

In 2003, when the company creates the ALMA LIGHT brand, he becomes responsible for broader areas such as product design, selection of proximity suppliers and control of manufacturing and its highest quality standards, always with a view to the evolution of the market, both in terms of design and purely technological and productive aspects. It is in the ALMA LIGHT project that Cristian Cubina can develop his skills as a designer, projecting the stands of the fairs in which the company participates as exhibitor and creating classic collections, such as

Obj (Javier Taberner & Nacho Poveda)

Studio borned in 2007 from the union of his two partners: Javier Taberner and Nacho Poveda. Their designs of furniture, product and lighting have been recognized with numerous prizes and distinctions in specialized publications, having spread to an international level. The studio also has participated in different exhibitions and events in different cities of Ibero-America, London, Madrid, Milan, Barcelona, Saint Etienne, etc.

Josep Puig Cabeza.

He studied Industrial Design at ELISAVA (Escuela Universitaria de Barcelona Diseño y Ingeniería) and obtained his degree in 1980. He later completed his degree at the University of Southampton (UK) where he graduated with honors as a Bachelor of Arts. He is a member of the Industrial Design Association of the Promotion of Arts and Design ADI-FAD and has been part of the Board of the Association on several occasions. He has taught courses and workshops in numerous design forums and is currently a professor at ELISAVA, where he has been leading the Master in Design and Product Development since 2006.

Josep Puig is a restless and brilliant designer whose creativity has developed in many areas. Among other initiatives, he is a founding member of the experimental design group "Transatlàntic" with Ramón Benedito and Lluís Morillas. In 1989 he embarked on the project "The Barna Crossing in Fukuoka" with "Alfredo Arribas Arquitectos Asociados", for the design of a collection of objects for a multimedia complex in Fukuoka,

Luminarias USB

USB Lamps

Bell / Cuadrat / Nautic / Patio / Tribeca USB







Tribeca USB

Design by Jordi LLopis

Pantalla alabastro
Shade alabaster

Estructura hierro galvanizado pintado epoxi texturizado
Structure galvanized iron textured epoxy painted

Luminaria con batería de polímero de Litio. Autonomía 7h, carga completa 5h. Cargador USB, entrada tipo Micro-B no incluido (ver referencias abajo). Led integrado. ON/OFF/Touch dimmer
Lithium polymer battery 7h autonomy. Complete charge 5h. USB charger, port type Micro-B not included (See codes below). Integrated Led. ON/OFF/Touch Dimmer

1800/011 24cm blanco texturizado **textured white**

1800/012 24cm corten texturizado **textured corten**

1800/018 24cm negro texturizado **textured black**

1810/011 20cm blanco texturizado **textured white**

1810/012 20cm corten texturizado **textured corten**

1810/018 20cm negro texturizado **textured black**

LED 1,3W 150lm 3000K

9995/010 Cargador USB simple 5V 2A + cable USB de 1,5mt entrada tipo Micro-B **Single 5V 2A charger + 1.5m USB cable port type Micro-B**

9996/060 Cargador múltiple 5V 12A + 6 x cable USB de 1,5mt entrada tipo Micro-B **Multiple charger 5V 12A + 6 x 1.5m USB cable port type Micro-B**

CE  IP 45

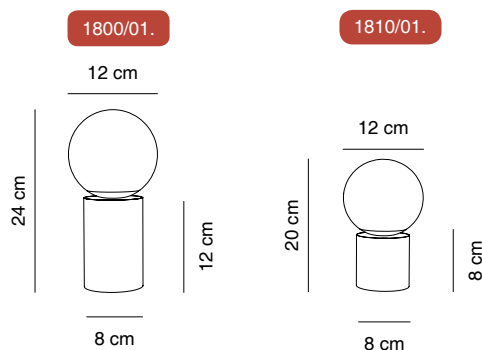

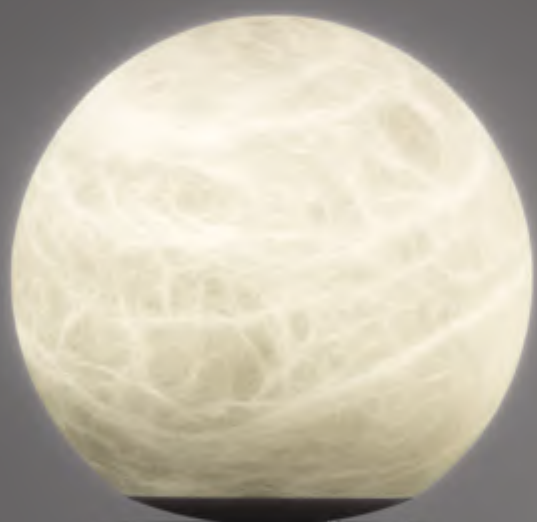







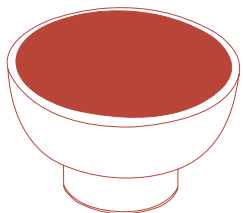

Elegante / Funcional
Fashionable / Useful



Los acabados de la luminaria PATIO, así como su diseño sereno y nada estridente, le confieren una gran elegancia aparte de su funcionalidad, al poderse colocar en cualquier sitio independientemente de tener una toma de corriente cercana. El difusor está fabricado en polietileno rotomoldeado en color natural y el cuerpo es de aluminio arenado y anodizado, disponible en dos versiones: plata y oro.

The finishes of the PATIO lamp, as well as its serene and smart design, give it great elegance apart from its functionality, as it can be placed anywhere regardless of having a plug nearby. The diffuser molded polyethylene in natural color and the body is made of sandblasted and anodized aluminium, available in two versions: silver and gold.

Se puede suministrar:

- Sin cable cargador (se puede usar el de un teléfono móvil).
- Con 1 cargador y 1 cable USB para 1 luminaria.
- Con 1 cargador múltiple con 6 cables USB para cargar simultáneamente 6 luminarias.

It can be ordered:

- ***Without charger (the charger from a mobile phone can be used).***
- ***With 1 charger and 1 USB cable for 1 lamp***
- ***With 1 multiple charger and 6 USB cables to simultaneously charge 6 lamps.***





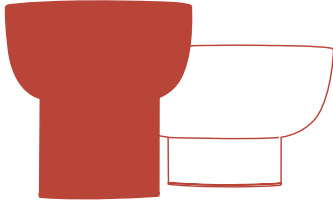

Usb / Inalámbrico *Usb / Wireless*



PATIO es una luminaria sin cables pensada para iluminar una mesa, ya sea en interior como en exterior, sin necesidad de disponer de una toma de corriente. Una aplicación ideal para hostelería y hotelería.

Utiliza una fuente de luz LED de 3W con un rendimiento máximo de 260 lúmenes. Gracias a su pantalla en polietileno rotomoldeado, esta luz se disipa homogéneamente iluminando el espacio sin sombras y la cubierta de aluminio anodizado evita el deslumbramiento de los comensales. Dispone de una batería de li-ion que permite una autonomía de máxima de 17 horas que se carga mediante un conector Micro USB (igual que el de un teléfono móvil) situado en la base. También dispone de un pulsador de encendido y apagado con tres posiciones de encendido, para ajustar la luz según la necesidad de cada momento. La base dispone de unos topes de silicona para evitar que la luminaria se deslice, en caso que la superficie de apoyo no sea estable, como en caso de barcos o autocaravanas.



PATIO is a wireless lamp ideal for installations, designed to illuminate a table, either indoors or outdoors, without the need of a plug. Perfect for its use in hotels, restaurants, terraces...

It uses a 3W LED light source with a maximum output of 260 lumens. Thanks to its polyethylene rotomolded shade, the light is dissipated evenly illuminating the space without shadows and the aluminium cover prevents the glare to the people sitting around the table. It houses a li-ion battery that allows 17 hours of authonomy, that is charged with a USB charger (like the ones used for mobile phones) located at the base. Besides it has an on-off switch with three positions to adjust the light according to the needs of each moment. The base has silicone stoppers to prevent the luminaire to slide, in case the surface is not stable, as in boats or mobile homes.





Patio

Design by Oriol LLahona

Pantalla polietileno rotomoldeado
Shade molded polyethylene

Estructura aluminio anodizado
Structure anodized aluminium

Luminaria con batería Li-ion. Autonomía intensidad baja 17h, intensidad media 7h, intensidad alta 4h. Carga completa 8h. Cargador USB, entrada tipo Micro-B no incluido (ver referencias abajo).

Led integrado. ON/OFF dimmer 3 posiciones.

Lit-ion battery lamp. low intensity 17h, medium intensity 7h, high intensity 4h Total charge 8h. USB charger, port type Micro-B not included (See codes below). Integrated Led. ON/OFF 3 steps Dimmer

2000/010 16,50cm dorado mate **matt gold**

2000/016 16,50cm plata mate **matt silver**

2010/010 12,50cm dorado mate **matt gold**

2010/016 12,50cm plata mate **matt silver**

LED 5V 1.2A - max.3W 260lm 3000K

9995/010 Cargador USB simple 5V 2A + cable USB de 1,5mt entrada tipo Micro-B **Single 5V 2A charger + 1.5m USB cable port type Micro-B**

9996/060 Cargador múltiple 5V 12A + 6 x cable USB de 1,5mt entrada tipo Micro-B **Multiple charger 5V 12A + 6 x 1.5m USB cable port type Micro-B**



2010/010
2010/016

2000/010
2000/016

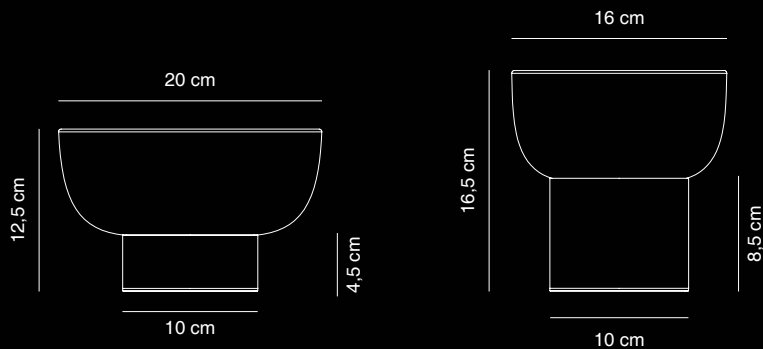







Bell

Design by Cristian Cubiñá

Pantalla de latón arenado
Shade sandblasted brass

Estructura madera maciza de Iroco
Structure massive Iroco wood

Luminaria con batería de polímero de Litio. Autonomía 7h, carga completa 5h. Cargador USB, entrada tipo Micro-B no incluido (ver referencias abajo).
Led integrado. ON/OFF/Touch dimmer
**Lithium polymer battery 7h autonomy. Complete charge 5h. USB charger, port type Micro-B not included (See codes below).
Integrated Led. ON/OFF/Touch Dimmer**

2050/010 redondo **round**

LED 1,3W 150lm 3000K

9995/010 Cargador USB simple 5V 2A + cable USB de 1,5mt entrada tipo Micro-B **Single 5V 2A charger + 1.5m USB cable port type Micro-B**

9996/060 Cargador múltiple 5V 12A + 6 x cable USB de 1,5mt entrada tipo Micro-B **Multiple charger 5V 12A + 6 x 1.5m USB cable port type Micro-B**

CE  IP 45

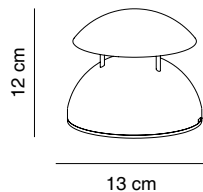















Cuadrat

Design by Josep Novell & Ernest Perera

Pantalla polietileno rotomoldeado

Shade textured rotomoulded polyethylene

Estructura de hierro pintado texturizado

Structure textured epoxy painted iron

Luminaria con batería de polímero de Litio. Autonomía 7h, carga completa 5h. Cargador USB, entrada tipo Micro-B no incluido (ver referencias abajo). Led integrado. ON/OFF/Touch dimmer

Lithium polymer battery 7h autonomy. Complete charge 5h. USB charger, port type Micro-B not included (See codes below). Integrated Led. ON/OFF/Touch Dimmer

2160/011 blanco texturizado **textured white**

2160/012 corren texturizado **textured corten**

2160/018 antracita texturizado **textured anthracite**

LED 1,3W 150lm 3000K

9995/010 Cargador USB simple 5V 2A + cable USB de 1,5mt entrada tipo Micro-B **Single 5V 2A charger + 1.5m USB cable port type Micro-B**

9996/060 Cargador múltiple 5V 12A + 6 x cable USB de 1,5mt entrada tipo Micro-B **Multiple charger 5V 12A 6 x 1.5m USB cable port type Micro-B**

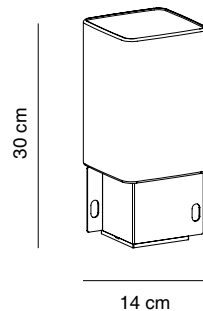

CE IP 45







Nautic

Design by Josep Novell & Ernest Perera

Pantalla polietileno rotomoldeado

Shade textured rotomoulded polyethylene

Estructura de aluminio pintado texturizado

Structure textured epoxy painted aluminium

Luminaria con batería de polímero de Litio. Autonomía 7h, carga completa 5h. Cargador USB, entrada tipo Micro-B no incluido (ver referencias abajo). Led integrado. ON/OFF/Touch dimmer

Lithium polymer battery 7h autonomy. Complete charge 5h. USB charger, port type Micro-B not included (See codes below). Integrated Led. ON/OFF/Touch Dimmer

5210/011 blanco texturizado **textured white**

5210/012 corten texturizado **textured corten**

5210/018 antracita texturizado **textured anthracite**

LED 1,3W 150lm 3000K

9995/010 Cargador USB simple 5V 2A + cable USB de 1,5mt entrada tipo Micro-B **Single 5V 2A charger + 1.5m USB cable port type Micro-B**

9996/060 Cargador múltiple 5V 12A + 6 x cable USB de 1,5mt entrada tipo Micro-B **Multiple charger 5V 12A + 6 x 1.5m USB cable port type Micro-B**

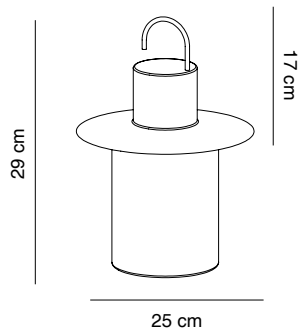

CE IP 45



Sobremesas Table Lamps

Aspen / Blow / Candle / Deco / Fuji / Hotel / MiniSpot / Paros Alabaster /
Star / Tribeca



MiniSpot

Design by Cristian Cubiñá

Estructura hierro pintado texturizado
Structure iron textured painted

Regulable mediante touch dimmer
Dimmable by touch dimmer

Led integrado **Integrated Led**

2525/011 blanco **white**

2525/018 negro **black**

LED Cree 3W 260lm 3000K CRI>90

CE IP 20

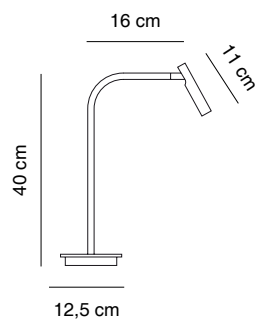



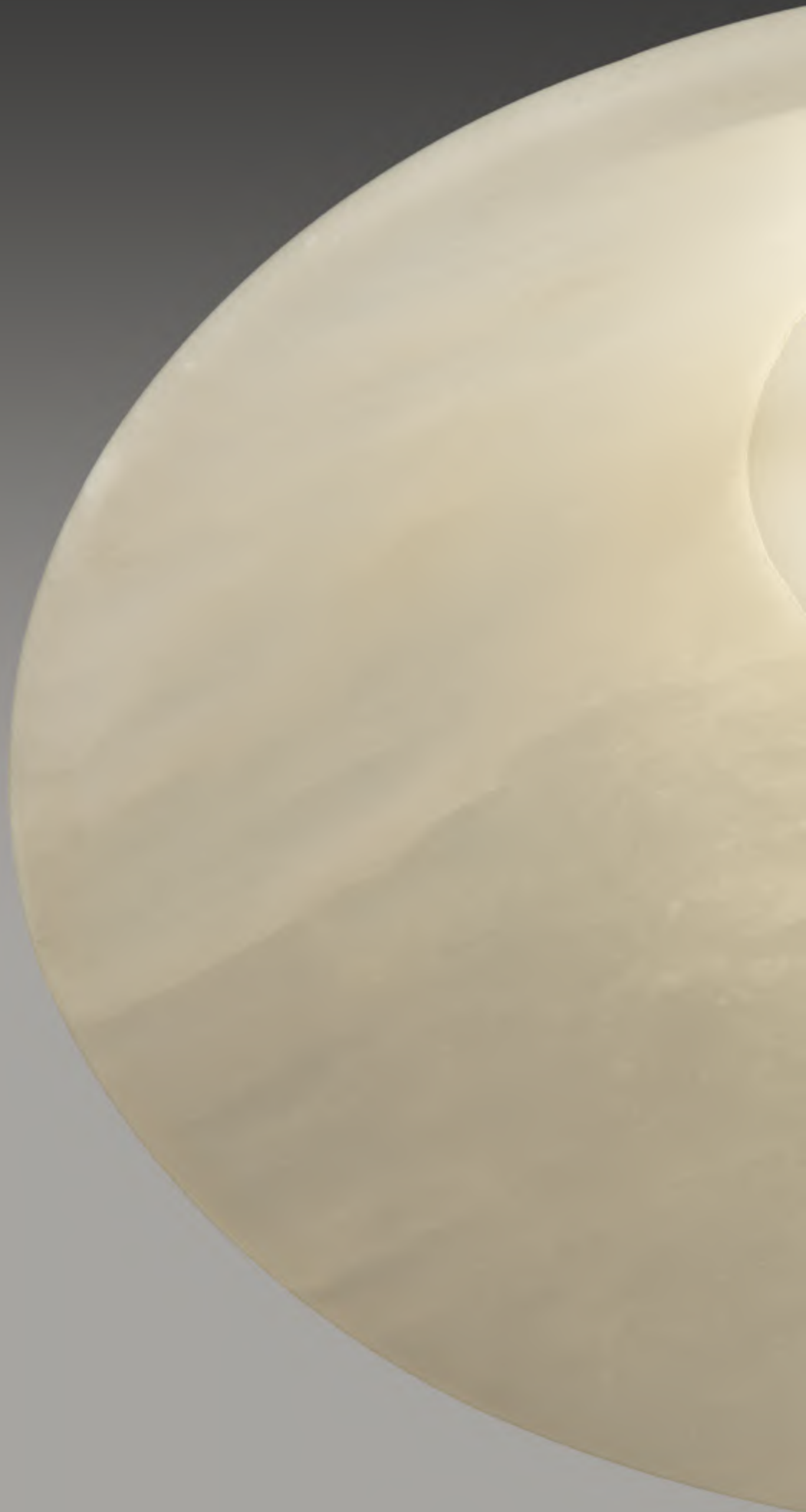



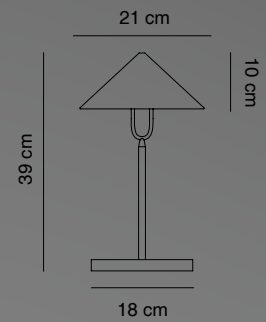

Fuji

Design by Jordi LLopis

Pantalla alabastro
Shade alabster

Estructura hierro baño electrolítico latón pulido
brillo
**Structure iron with electrolytic bath in polis-
hed brass finish**

Sin regulador. Versión dimable bajo pedido
**Without dimmer. Dimmable version upon
request**

Led integrado
Integrated Led

2070/010

LED Seoul 4,6W 260lm 2700K

CE  





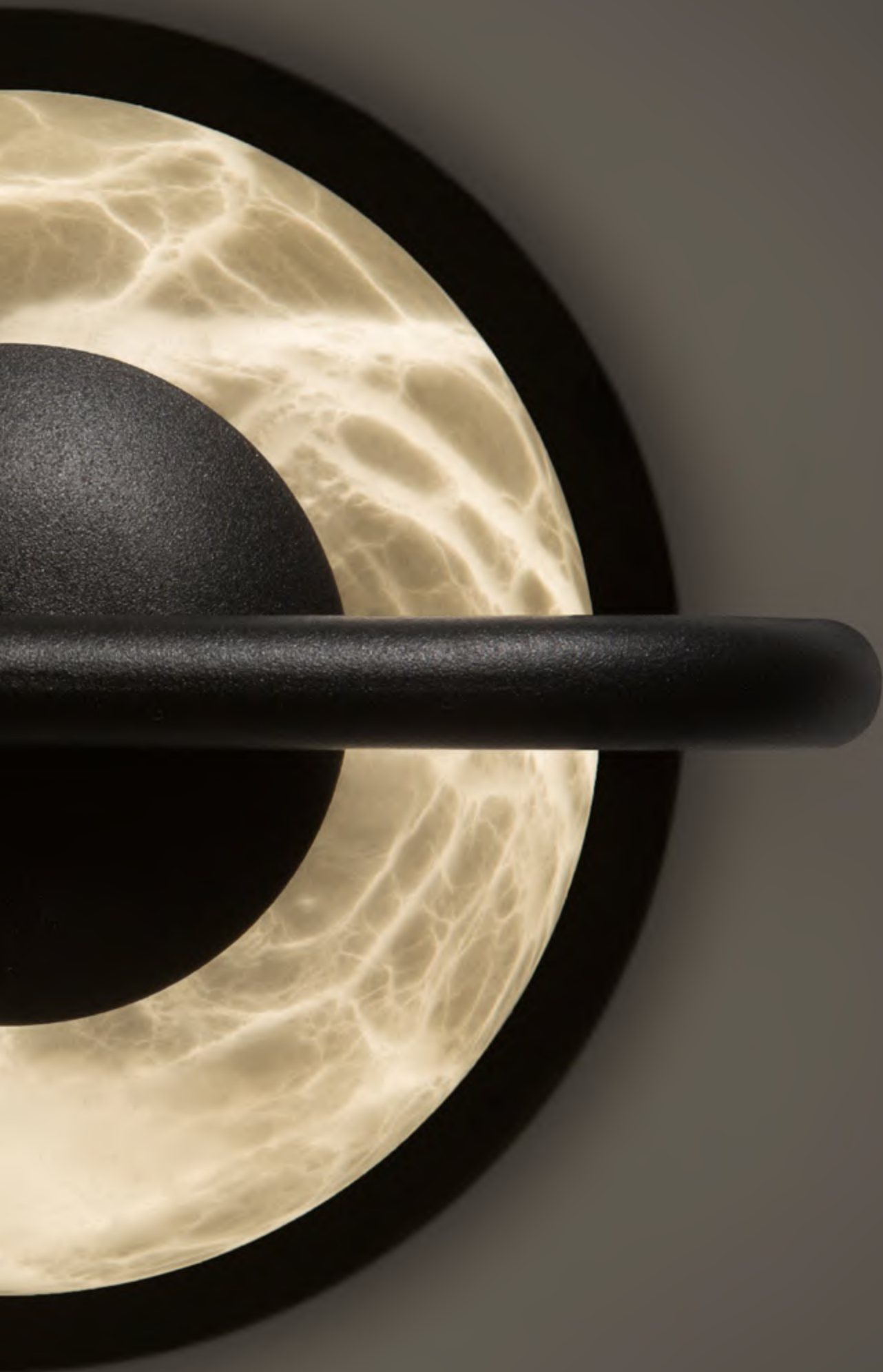



Tribeca

Design by Jordi LLopis

Pantalla alabastro
Shade alabaster

Estructura hierro pintado negro texturizado
Structure black textured epoxy painted iron

LED integrado
Integrated LED

No regulable **Not dimmable**
2800/018

Regulable. Driver enchufable
Dimmable. Plug in driver
2800/018RG

LED Seoul 4.5W 270lm 2700K

CE IP 20

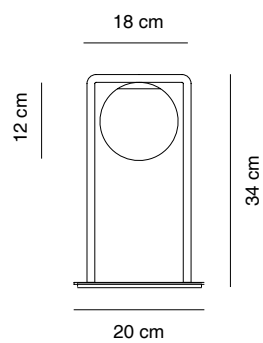



La otra mujer

Andrés Martín

El mundo es un teatro / Nuestra vida es un teatro

El mundo es un teatro / Nuestra vida es un teatro





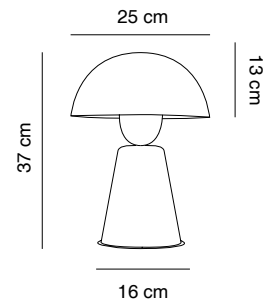

Star

Design by Cristian Cubiña

Pantalla metacrilato opal
Shade opal methacrylate

Estructura hierro pintado brillante
Structure gloss iron painted

Regulador-interruptor incluido en el cable
Switch-dimmer in cable included

Lámpara no incluida
Lamp not included

2085/011 blanco brillante **glossy white**

2085/018 negro brillante **glossy black**

 E27 LED

CE  







Paros Alabaster

Design by Josep Novell & Ernest Perera

Pantalla alabastro
Shade alabaster

Estructura hierro pintado blanco texturizado
Structure textured white painted iron

Sin regulador **without dimmer**

Lámpara no incluida
Lamp not included

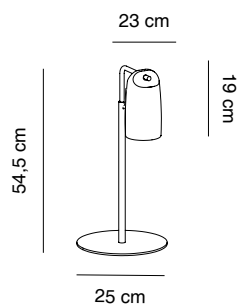

2270/011

 E14 / LED

CE  





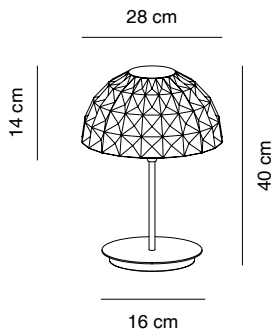

Deco

Design by Cristian Cubiñá

Pantalla cristal prensado de Bohemia en acabado transparente
Shade Pressed Bohemia crystal in transparent finish

Estructura hierro cromado
Structure chromed iron

Sin regulador **Without dimmer**

Lámpara no incluida
Lamp not included

2550/011 cromo **chrome**

2530/011 dorado brillo **polished gold**

 E14 LED

CE  IP 20





Candle

Design by Cristian Cubiñá

Cristal soplado triplex opal
Opal triplex blown glass

Regulador touch dimmer *with Touch dimmer*

LED integrado
Integrated LED

2250/011 blanco mate ***matt white***

2250/016 níquel satinado ***satin nickel***

2250/017 cromo ***chrome***

LED 6W 3000K

CE  

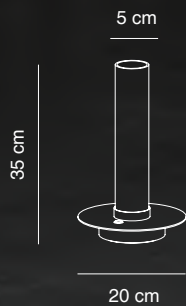



Hotel

Design by Cristian Cubiñá

Estructura hierro acabado níquel satinado
Structure satin nickel iron

Pantalla algodón negro
Shade black cotton

Sin regulador **Without dimmer**

Lámpara no incluida
Lamp not included

2540/018

 E27 LED

CE  

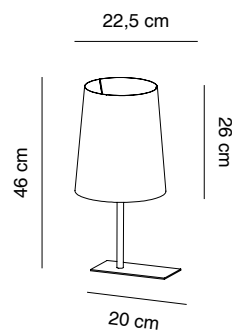





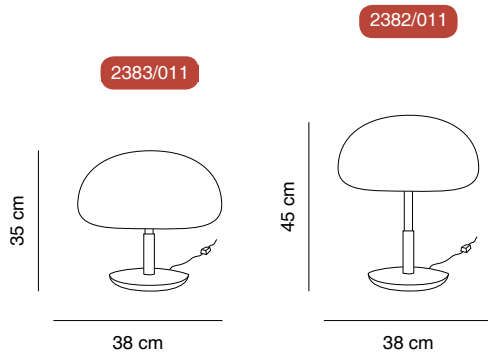

Aspen

Design by Javier Taberner & Nacho Poveda

Pantalla cerámica esmaltada brillante
Shade shiny enamelled ceramic

Estructura madera de roble / hierro pintado epoxi
/cable textil

**Structure oak wood / epoxy painted iron /
textile cable**

Sin regulador **Without dimmer**

Lámpara no incluida
Lamp not included

2382/011

2383/011

 3xE14 LED

CE  

Lámparas de pie Floor Lamps

Big Brother / Blow / Deco / Fuji / Hotel / Led Pole / MiniSpot / Paros Alabaster
/ Star / Tribeca / Totem I / Totem II / Work



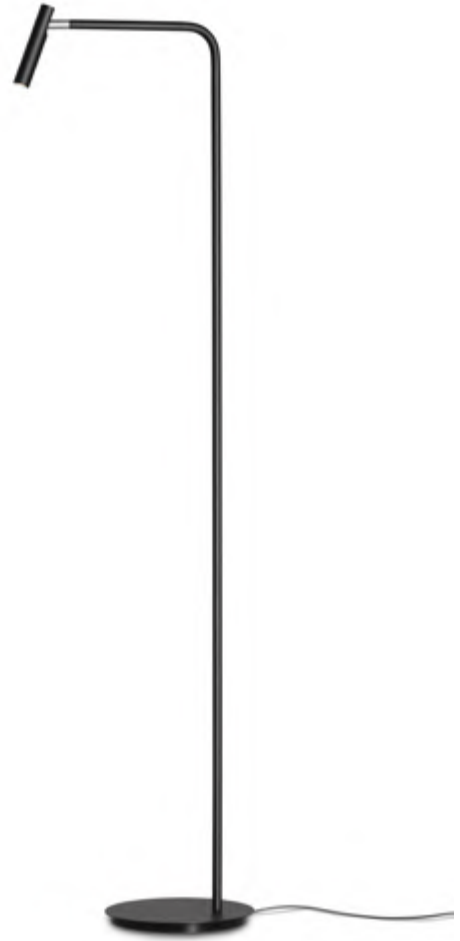

MiniSpot

Design by Cristian Cubiñá

Estructura hierro pintado texturizado

Structure iron textured painted

Regulable mediante touch dimmer

Dimmable by touch dimmer

Led integrado **Integrated Led**

3525/011 blanco **white**

3525/018 negro **black**

LED Cree 3W 260lm 3000K CRI>90

CE IP 20

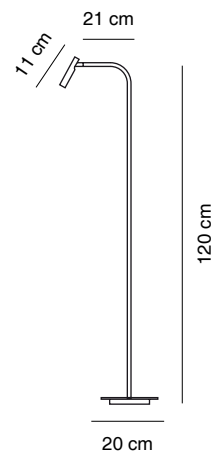



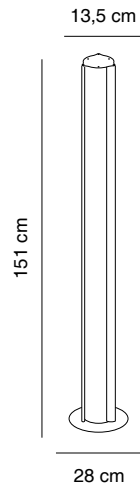

Totem II

Design by Cristian Cubiña

Pantalla cristal de borosilicato estriado transparente
Shade transparent fluted borosilicate glass

Estructura hierro pintado epoxi texturizado o baño electrolítico
Structure textured painted or electroplated iron

Regulador con interruptor incluido en el cable
Switch - dimmer in cable included

LED integrado
Integrated LED

3333/012 bronce satinado **satin bronze**

3333/018 negro texturizado **textured black**

LED 230V 16W 1520lm 2700K >90CRI

CE IP 20







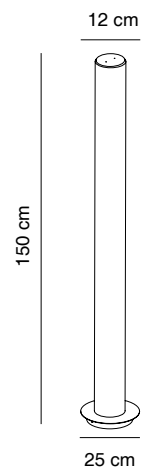
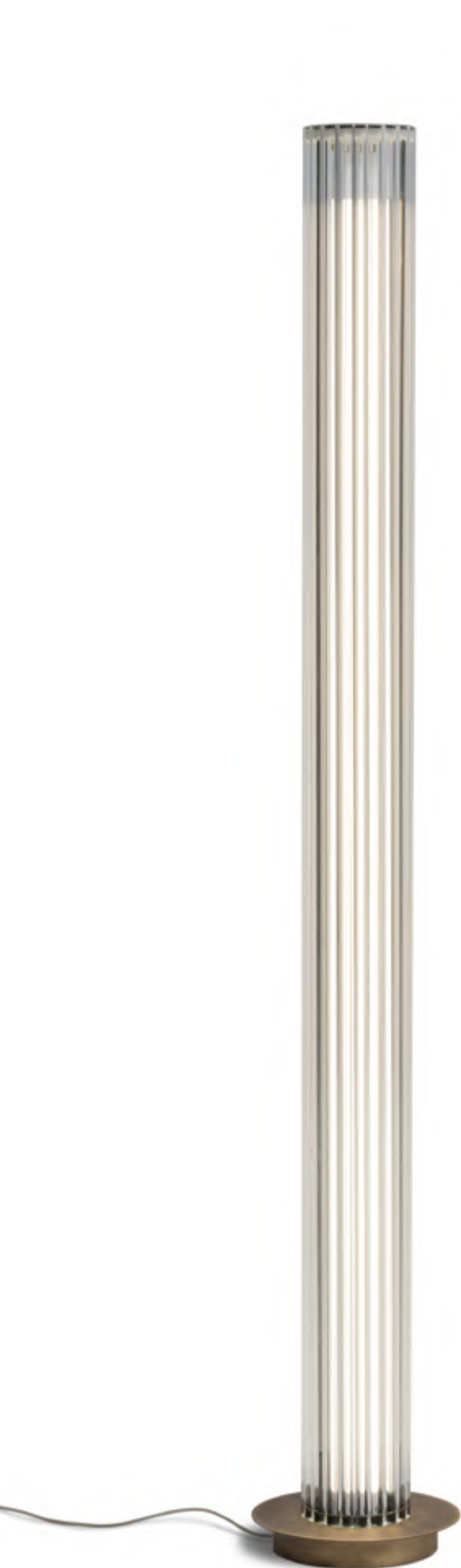

Totem I

Design by Cristian Cubiña

Pantalla cristal de borosilicato estriado transparente
Shade Transparent fluted borosilicate glass

Estructura: Hierro pintado epoxi texturizado o
baño electrolítico **Structure Textured painted or
electroplated iron**

No regulable. Versión regulable: contactar
Not dimmable. Dimmable version: please contact us

Lámpara no incluida
Lamp not included

3000/012 bronce satinado **satin bronze**

3000/018 negro texturizado **textured black**

☐ 2XG13 LED T8 150cm

CE ☐ IP 20







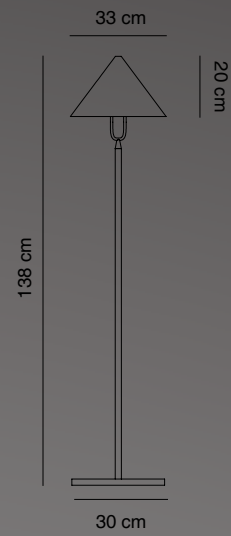
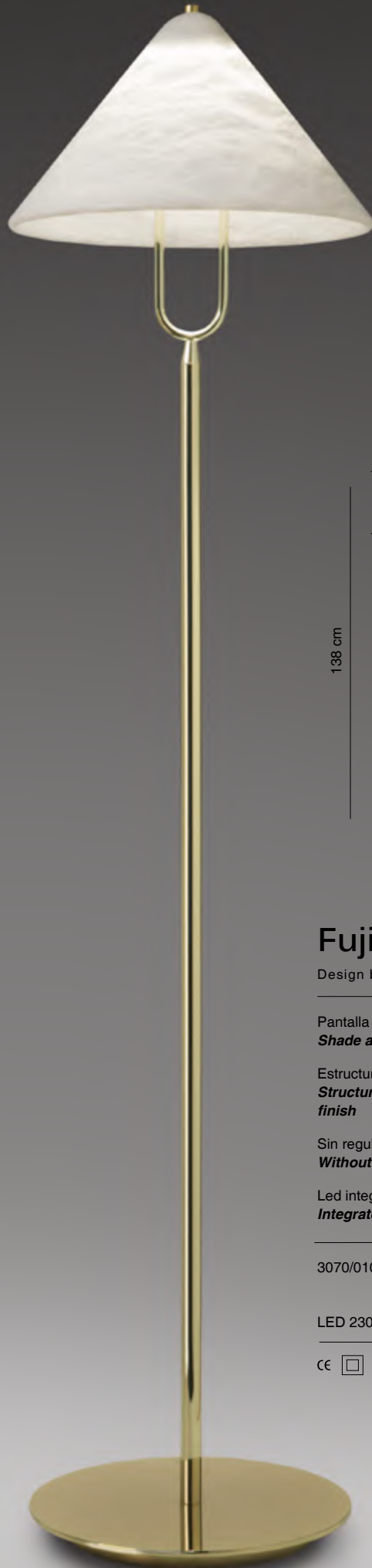

Fuji

Design by Jordi LLopis

Pantalla alabastro
Shade alabaster

Estructura hierro baño electrolítico latón pulido brillo
Structure iron with electrolytic bath in polished brass finish

Sin regulador. Versión regulable: consultar
Without dimmer. Dimmable version: please contact us

Led integrado
Integrated Led

3070/010

LED 230V 4,83W 335lm 2700K

CE  





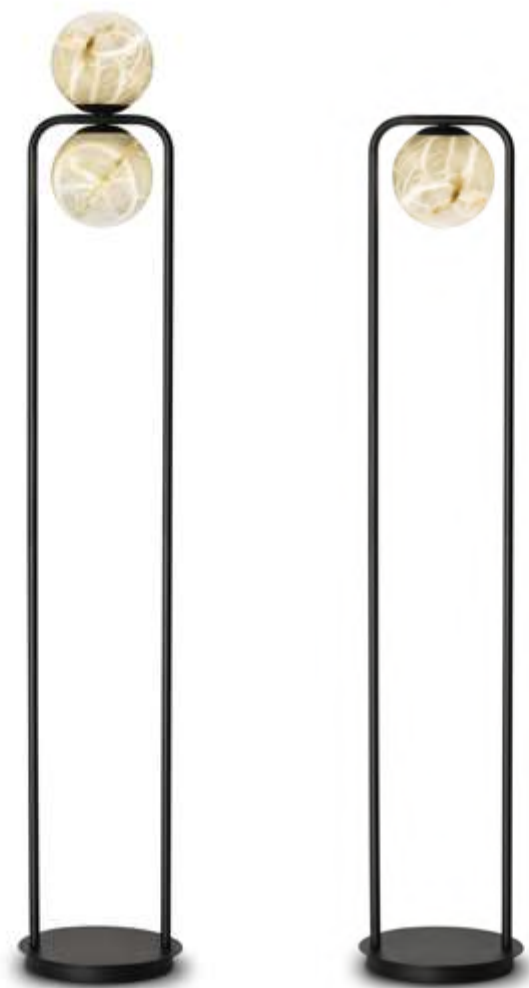

Tribeca

Design by Jordi LLopis

Pantalla alabastro
Shade alabaster

Estructura hierro pintado negro texturizado
Structure black textured epoxy painted iron

LED integrado
Integrated LED

No regulable **Not dimmable**

3800/018 108cm

3800/028 120cm

3810/028 180cm

Regulable. Driver enchufable

Dimmable. Plug in driver

3800/018RG 108cm

3800/028RG 120cm

3810/028RG 180cm

LED Seoul 4.5W 270lm 2700K

€ IP 20

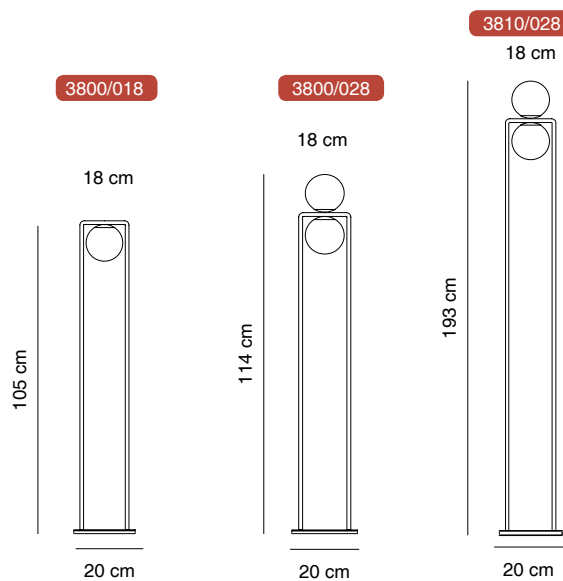







Star

Design by Cristian Cubiña

Pantalla metacrilato opal
Shade opal methacrylate

Estructura hierro pintado brillante
Structure gloss iron painted

Regulador-interruptor incluido en el cable
Switch-dimmer in cable included

Lámpara no incluida
Lamp not included

3085/011 blanco brillante **glossy white**

3085/018 negro brillante **glossy black**

 E27 LED

CE  

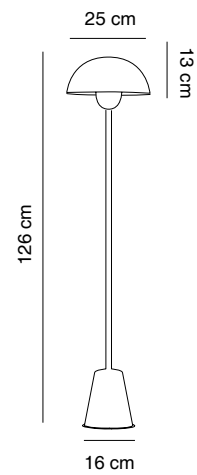





Paros Alabaster

Design by Josep Novell & Ernest Perera

Pantalla alabastro
Shade alabaster

Estructura hierro pintado blanco texturizado
Structure textured white painted iron

Sin regulador **without dimmer**

Lámpara no incluida, reemplazable
Lamp not included, replaceable

3270/011

 E14 LED

CE   IP 20

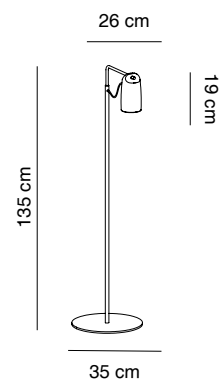

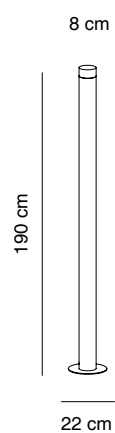
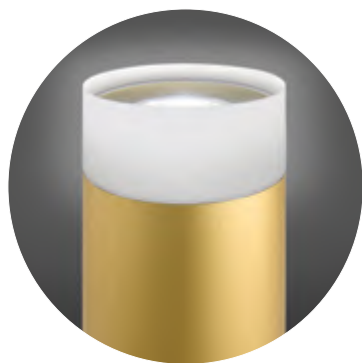

Led Pole

Design by Cristian Cubiñá

Pantalla metacrilato arenado
Shade sand blasted methacrylate

Estructura extrusión aluminio
Structure extruded aluminum

Regulador-interruptor incluido en el cable.
Switch-dimmer in cable included

LED integrado
Integrated LED

3160/011 blanco texturizado **textured white**

3160/018 negro texturizado **textured black**

3160/016 anodizado plata mate **anodized matt silver**

3160/010 anodizado dorado mate **anodized matt gold**

LED Talex Stark module 20W 3500lm 3000K

CE  

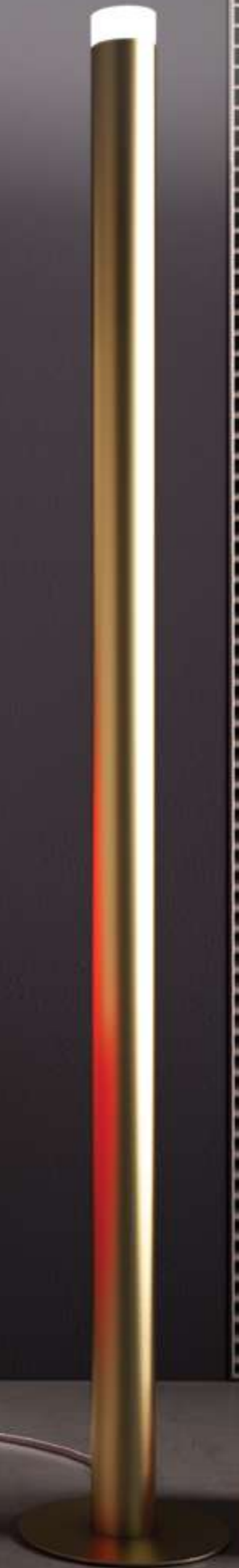









Big Brother

Design by Oriol Llahona

Pantalla textil de polipropileno blanco y asa en cuero grabado
Shade white polypropylene textile and engraved leather handle

Estructura hierro pintado blanco mate
Structure white painted iron

Regulador-interruptor incluido en el cable
Switch-dimmer in cable included

Lámpara no incluida
Lamp not included

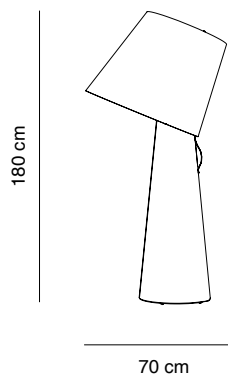

3950/011

 3 X E27 LED

CE  

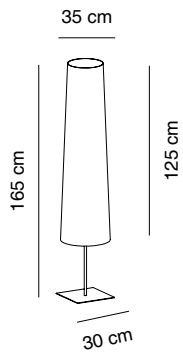

Hotel

Design by Cristian Cubiñá

Pantalla algodón negro
Shade black cotton

Estructura hierro acabado níquel satinado
Structure satin nickel iron

Sin regulador **without dimmer**

Lámpara no incluida
Lamp not included

3540/018

 E27 LED

CE  



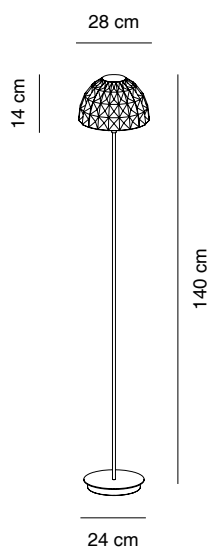

Deco

Design by Cristian Cubiñá

Pantalla cristal prensado de Bohemia en acabado transparente
Shade Pressed Bohemia crystal transparent glass

Estructura hierro cromado
Structure chromed iron

Sin regulador **Without dimmer**

Lámpara no incluida
Lamp not included

3550/011 cromo **chrome**

3530/011 dorado brillo **polished gold**

 E14 LED

CE  



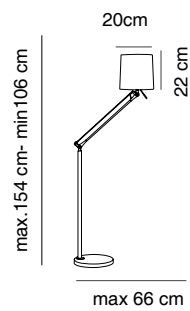

Work

Pantalla textil almadén plata
Shade silver almadén textile

Estructura aluminio anodizado plata mate
Structure aluminium matt silver anodized

Sin regulador **Without dimmer**

Lámpara no incluida
Lamp not included

4245/019

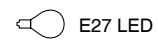

CE  



Suspensiones Hanging Lamps

Bath A Led / Biscuit / Blow / Deco / Drop Led / Fuji / Led Box / Led Oval
/ Lens Led / Moon / Paros Alabaster / Soft / Stone Led / SuperMoon /
TheChandelier / TheLight / ThePalm / Totem II / Tribeca





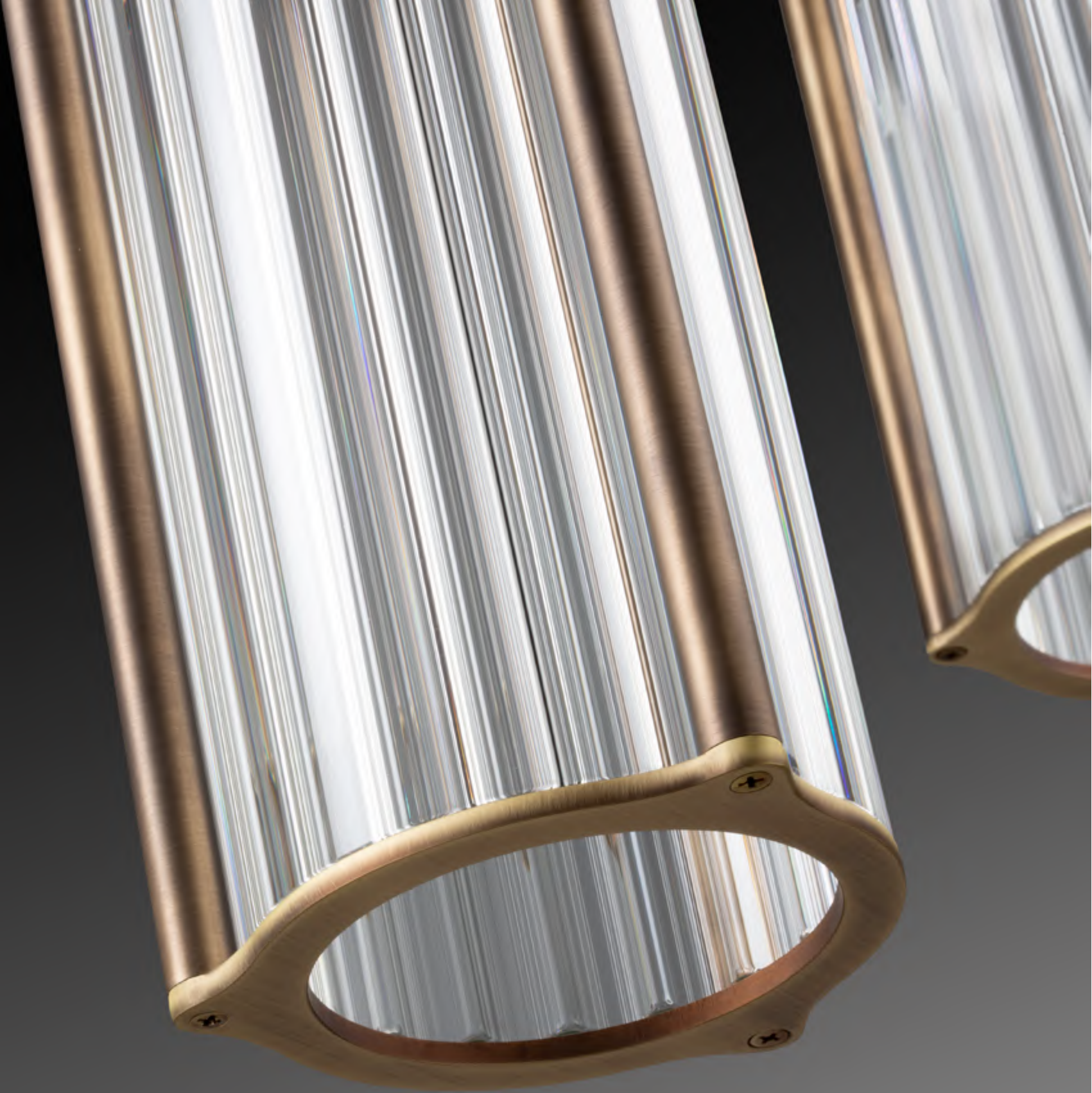



Totem II

Design by Cristian Cubiña

Pantalla cristal de borosilicato estriado transparente
Shade transparent fluted borosilicate glass,

Estructura hierro pintado texturizado o baño electrolítico
Structure textured painted or electroplated iron

Regulable mediante Triac
Dimmable by Triac

LED integrado
Integrated LED

5335/012 bronce satinado **satin bronze 25cm**

5335//018 negro texturizado **textured black 25cm**

5336/012 bronce satinado **satin bronze 50cm**

5336/018 negro texturizado **textured black 50cm**

LED 230V 16W 1520lm 2700K >90CRI

5333/012 bronce satinado **satin bronze 25cm**

5333//018 negro texturizado **textured black 25cm**

5334/012 bronce satinado **satin bronze 50cm**

5334/018 negro texturizado **textured black 50cm**

LED 230V 10W 920lm 2700K >90CRI

CE  

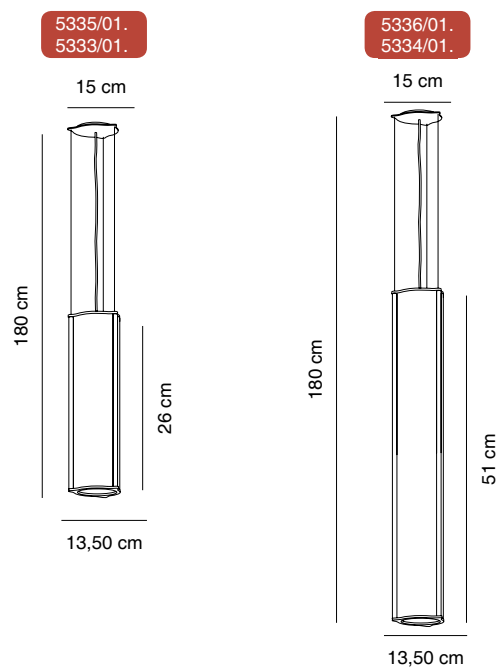

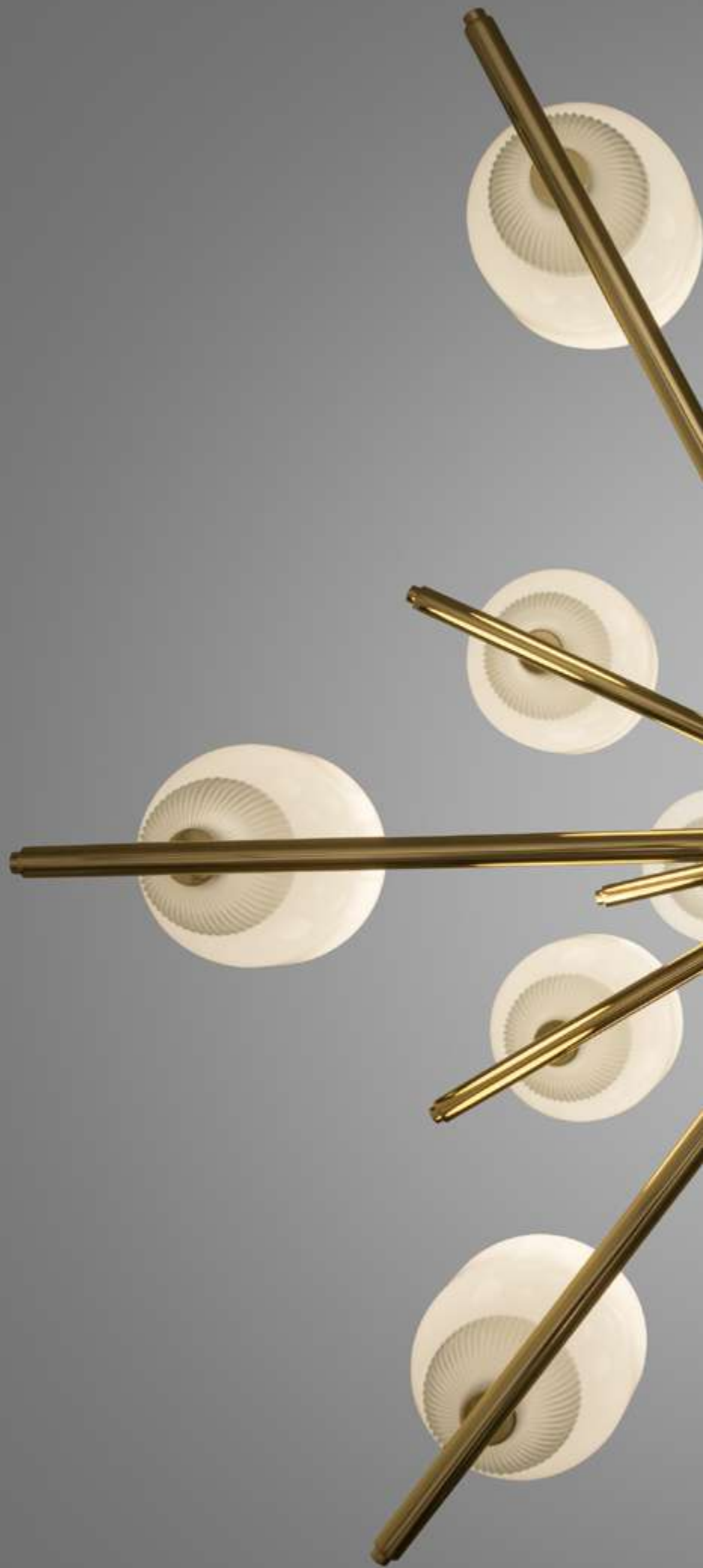





















TheChandelier

Design by Alfonso de la Fuente (Pichiglas Studio)

Pantalla cristal opal
Shade opal glass

Estructura hierro
Structure iron

Lámparas no incluidas **Lamps not included**

5170/031 colgante 3 brazos blanco texturizado **pendant 3 arms textured white**

5170/038 colgante 3 brazos negro texturizado **pendant 3 arms textured black**

5170/030 colgante 3 brazos latón pulido brillo **pendant 3 arms polished brass**

5170/091 colgante 9 brazos blanco texturizado **pendant 9 arms textured white**

5170/098 colgante 9 brazos negro texturizado **pendant 9 arms textured black**

5170/090 colgante 9 brazos latón pulido brillo **pendant 9 arms polished brass**

5170/151 colgante 15 brazos blanco texturizado **pendant 15 arms textured white**

5170/158 colgante 15 brazos negro texturizado **pendant 15 arms textured black**

5170/150 colgante 15 brazos latón pulido brillo **pendant 15 arms polished brass**

 E27 LED

CE   IP 20

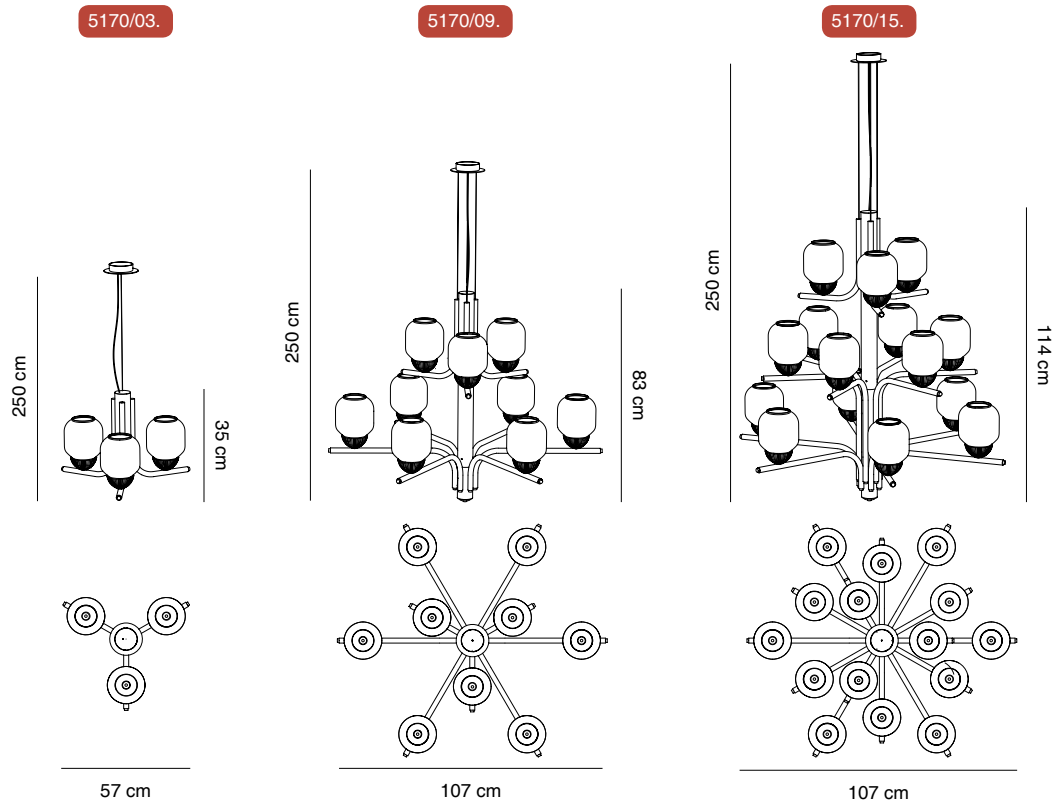









Fuji

Design by Jordi Llopis

Pantalla alabastro
Shade alabster

Estructura hierro baño electrolítico latón pulido brillo
Structure iron with electrolytic bath in polished brass finish

Lámpara incluida y no reemplazable
Lamp included and not replaceable

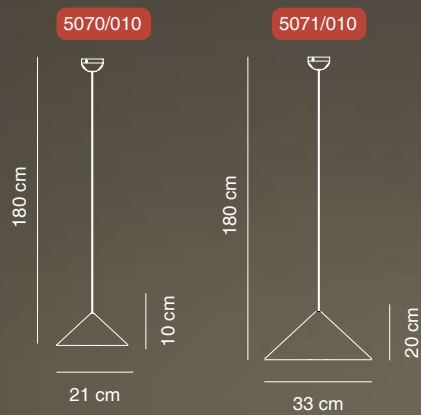

5070/010 no regulable **not dimmable**

LED Seoul 4,6W 2700K 260lm

5071/010 no regulable **Not dimmable**

LED 230V 4,85W 2700K 335lm

5070/010RG regulable **dimmable**

LED Seoul 4,6W 2700K 260lm

5071/010RG regulable **dimmable**

LED 230V 4,85W 335lm 2700K

CE IP 20

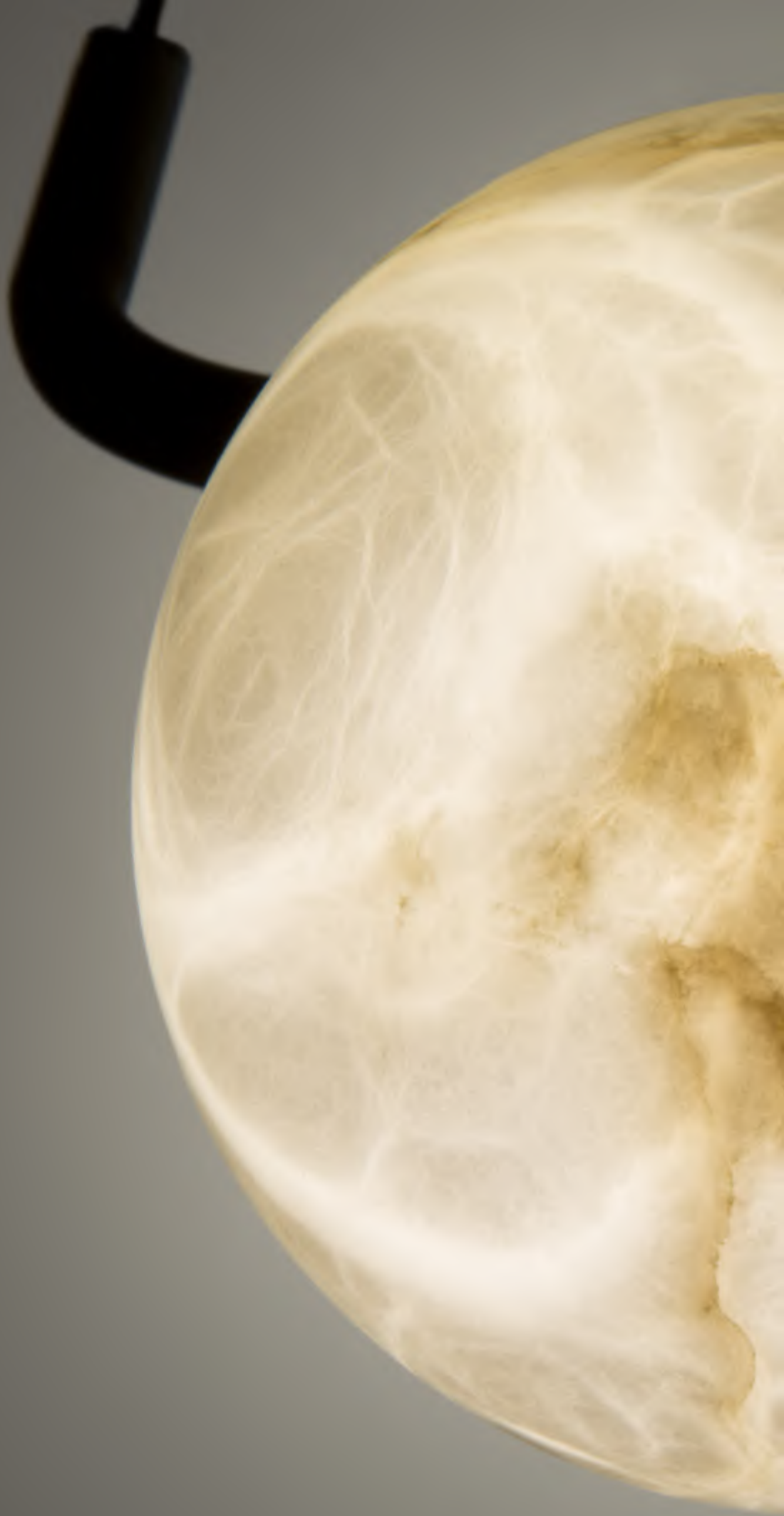







Tribeca

Design by Jordi LLopis

Pantalla alabastro
Shade alabaster

Estructura hierro pintado negro texturizado
Structure black textured epoxy painted iron

Led integrado
Integrated Led

No regulable **Not dimmable**

5800/018
5800/028

Regulable **Dimmable**

5800/018RG
5800/028RG

LED Seoul 4.5W 270lm 2700K

CE IP 20

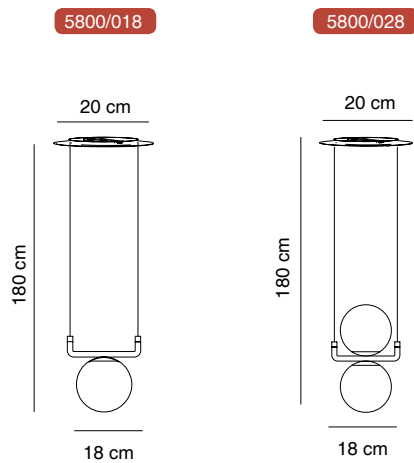



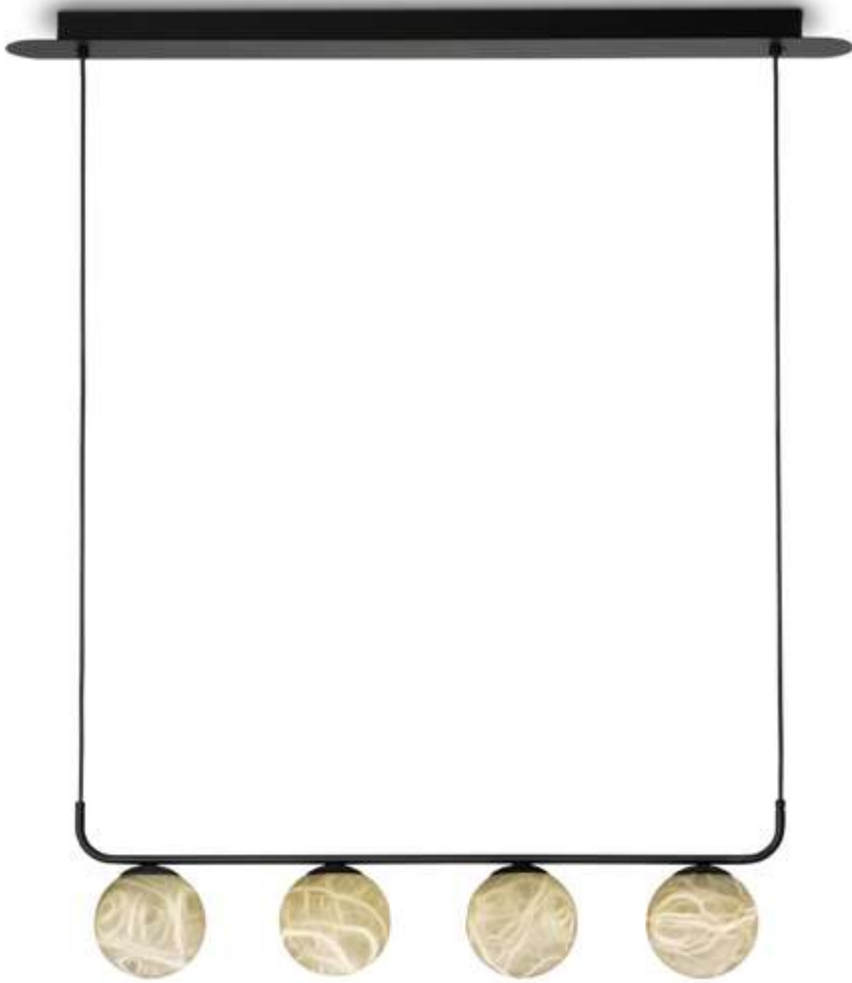

Tribeca

Design by Jordi LLopis

Pantalla alabastro
Shade alabaster

Estructura hierro pintado negro texturizado
Structure textured black painted iron

Led integrado
Integrated Led

No regulable **Not dimmable**

5800/048

Regulable **Dimmable**

5800/048RG

4 x LED Seoul 4,5W 270lm 2700K

CE IP 20

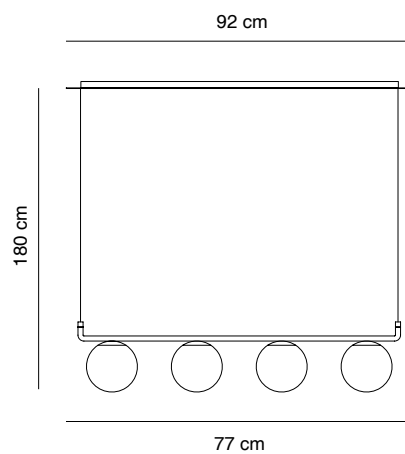



Paros Alabaster

Design by Josep Novell & Ernest Perera

Pantalla alabastro
Shade alabaster

Estructura hierro pintado blanco texturizado
Structure textured white painted iron

Lámpara no incluida
Lamp not included

5270/011

 E14 LED

CE  

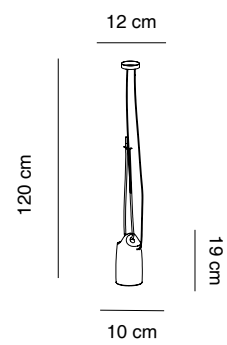











ThePalm

Design by Cristian Cubiñá

Pantalla metacrilato arenado
Shade sandblasted methacrylate

Estructura hierro
Structure iron

No regulable. Versión regulable: consltar
Not dimmable. Dimmable version: please contact us

Led integrado. Integrated Led

5190/121 22,9W 1889lm 2700K blanco texturizado **textured white**

5190/128 22,9W 1889lm 2700K negro texturizado **textured black**

5190/126 22,9W 1889lm 2700K níquel satinado **satin nickel**

5190/120 22,9W 1889lm 2700K dorado satinado **satin gold**

5190/181 34,34W 2834lm 2700K blanco texturizado **textured white**

5190/188 34,34W 2834lm 2700K negro texturizado **textured black**

5190/186 34,34W 2834lm 2700K níquel satinado **satin nickel**

5190/180 34,34W 2834lm 2700K dorado satinado **satin gold**

5190/301 57,24W 4723lm 2700K blanco texturizado **textured white**

5190/308 57,24W 4723lm 2700K negro texturizado **textured black**

5190/306 57,24W 4723lm 2700K níquel satinado **satin nickel**

5190/300 57,24W 4723lm 2700K dorado satinado **satin gold**

LED Seoul

CE IP 20

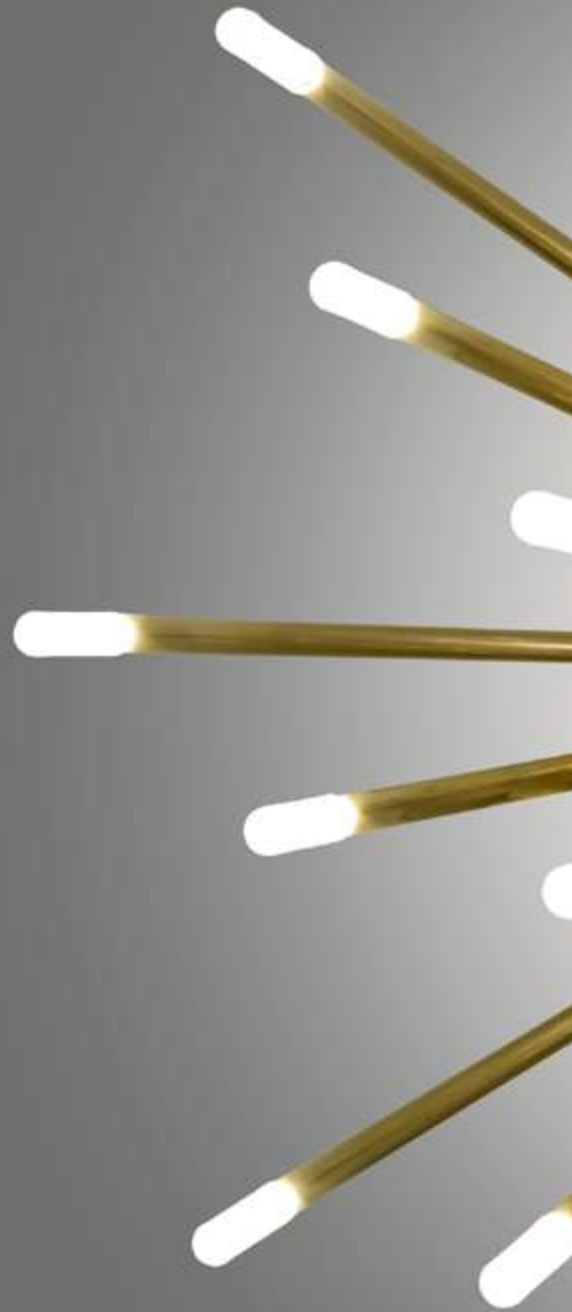
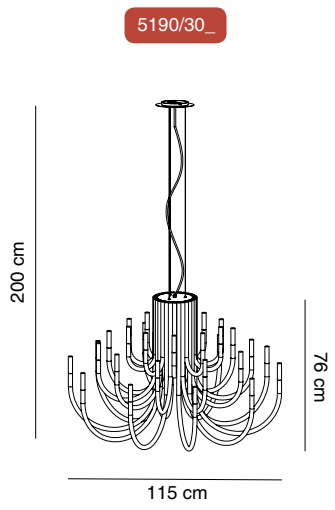
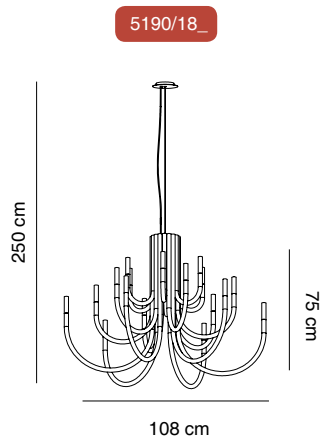
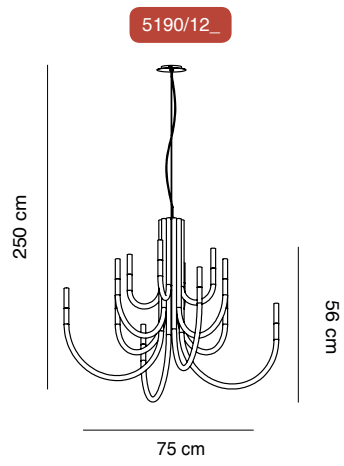

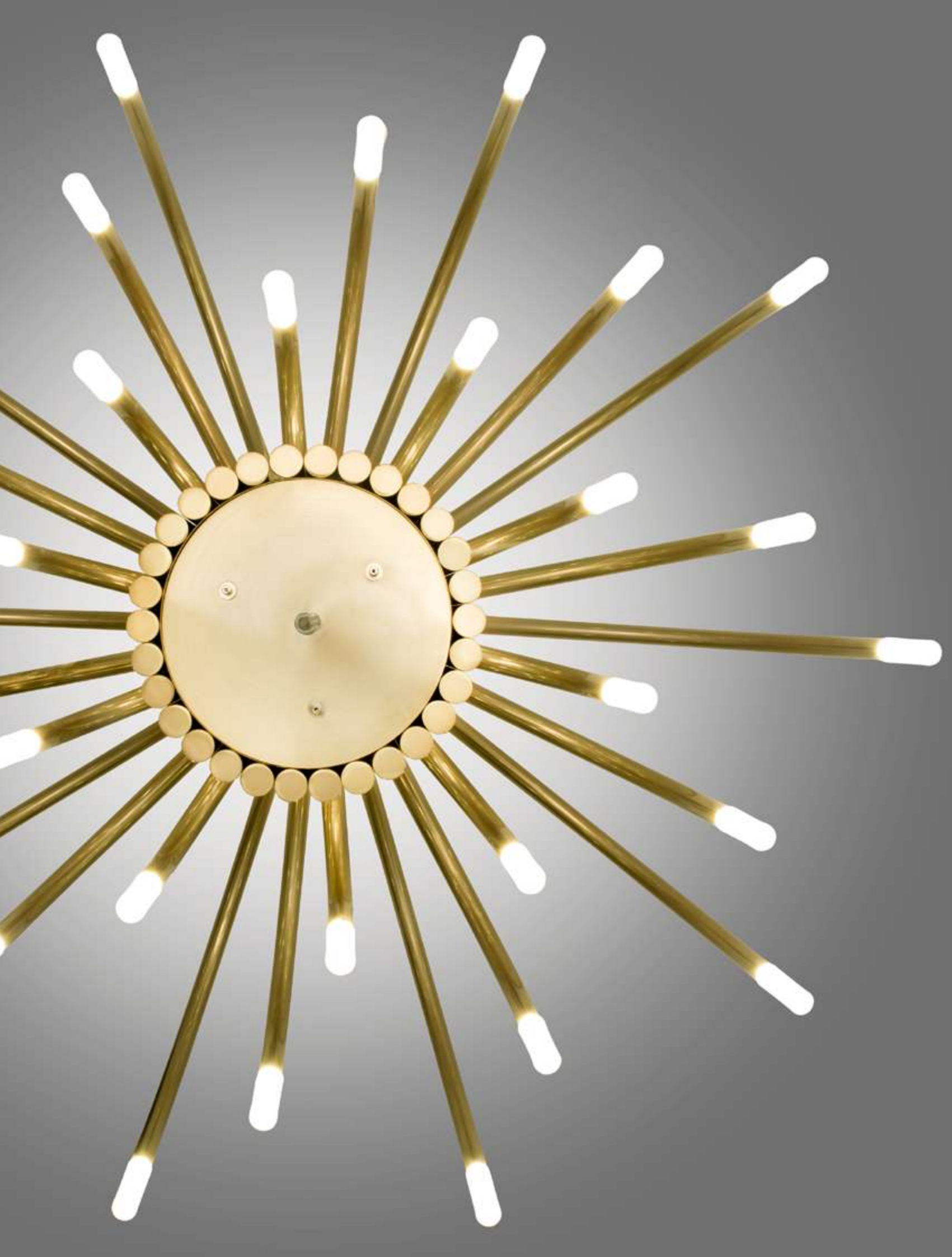







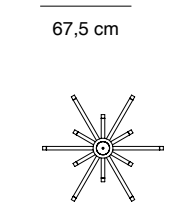
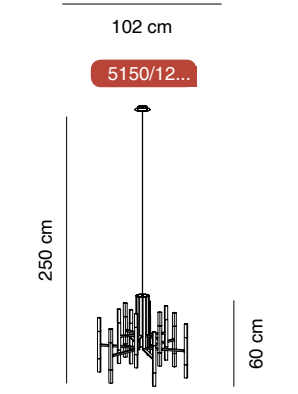
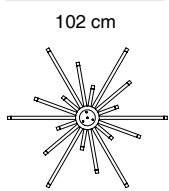
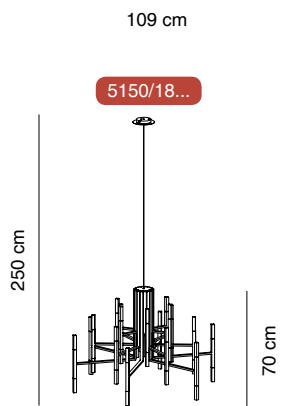
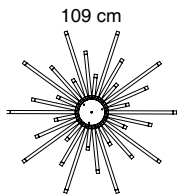
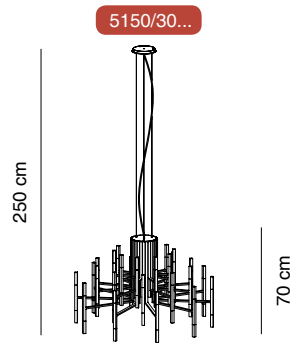

67,5 cm





TheLight

Design by Cristian Cubiñá

Estructura hierro
Structure iron

Pantalla metacrilato arenado
Shade sandblasted methacrylate

No regulable. Versión regulable: consltar
Not dimmable. Dimmable version: please contact us

Led integrado. **Integrated Led.**

5150/121 25,15W 2498lm 2700K blanco mate **matt white**
5150/128 25,15W 2498lm 2700K negro mate **matt black**
5150/126 25,15W 2498lm 2700K níquel satinado **satin nickel**
5150/120 25,15W 2498lm 2700K dorado satinado **satin gold**

5150/181 37,76W 3748lm 2700K blanco mate **matt white**
5150/188 37,76W 3748lm 2700K negro mate **matt black**
5150/186 37,76W 3748lm 2700K níquel satinado **satin nickel**
5150/180 37,76W 3748lm 2700K dorado satinado **satin gold**

5150/301 62,88W 6245lm 2700K blanco mate **matt white**
5150/301 62,88W 6245lm 2700K negro mate **matt black**
5150/306 62,88W 6245lm 2700K níquel satinado **satin nickel**
5150/300 62,88W 6245lm 2700K dorado satinado **satin gold**

LED Seoul

CE IP 20



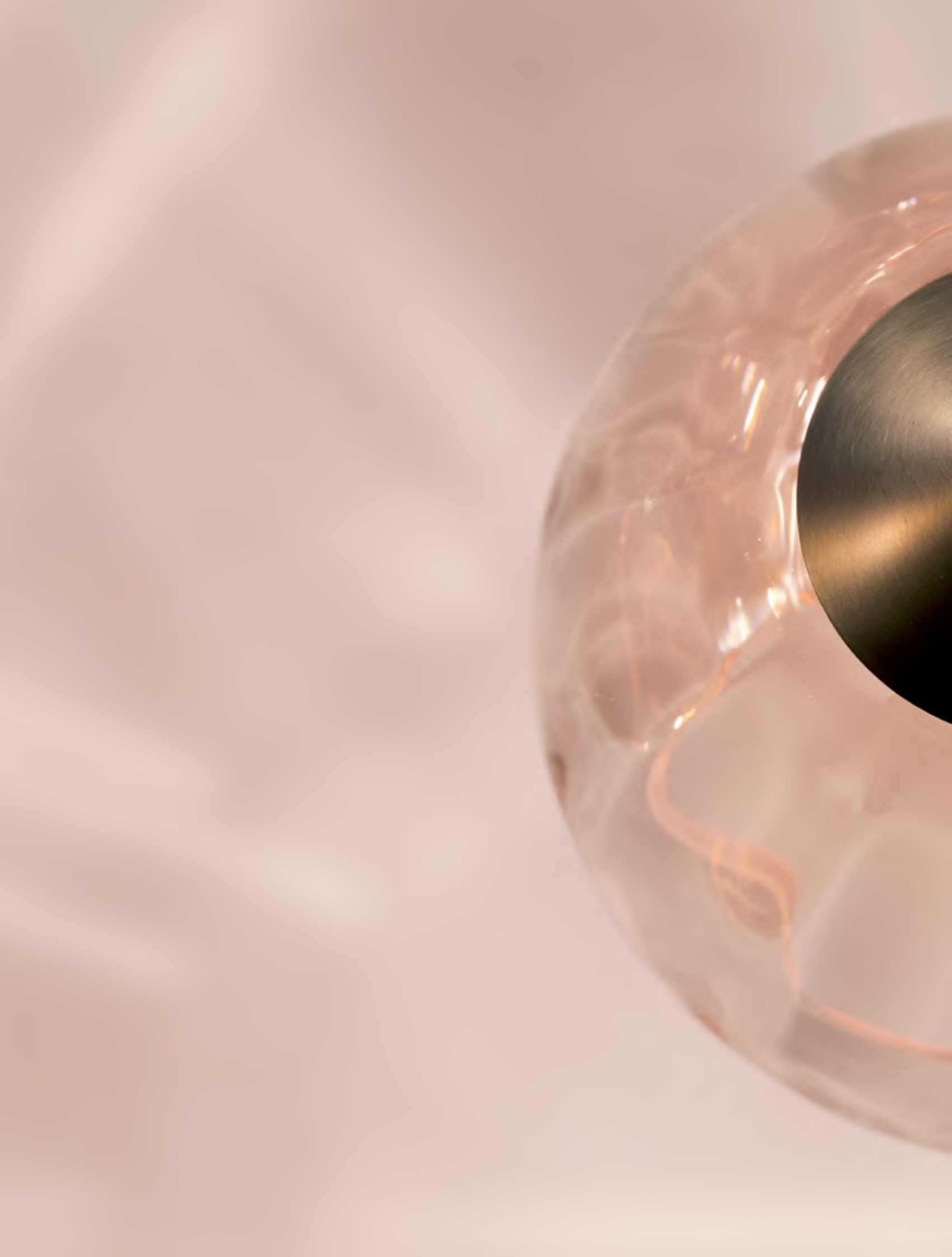



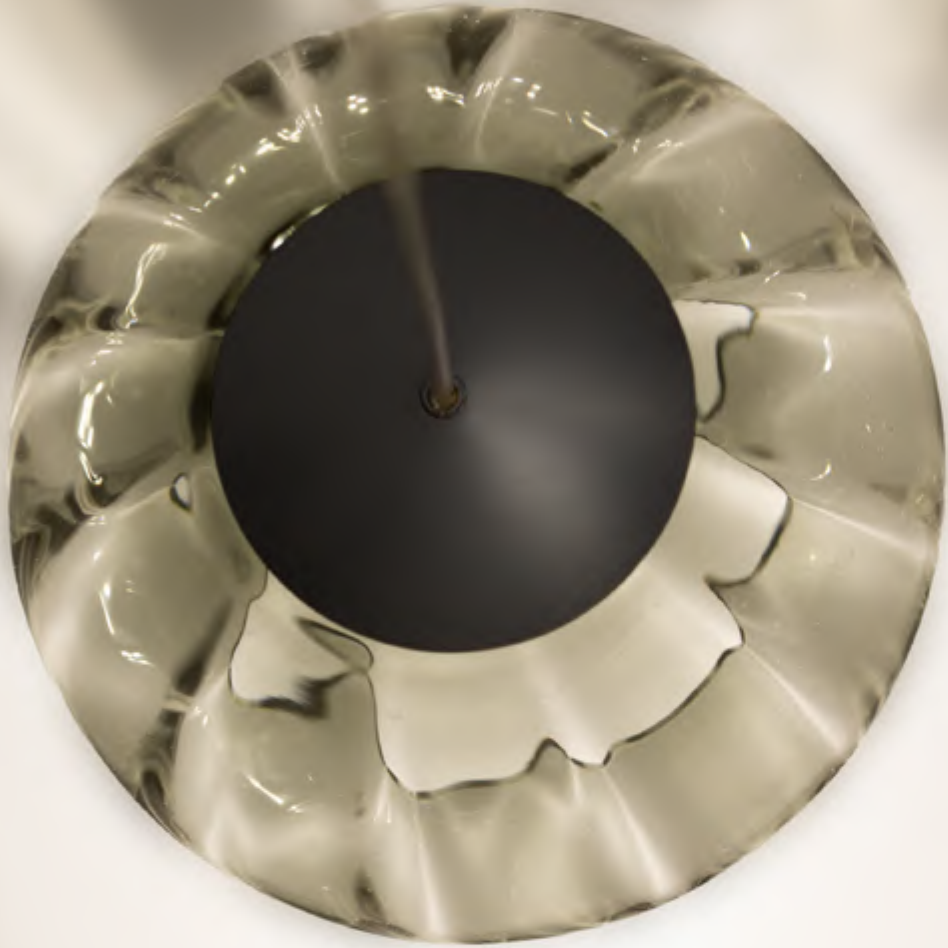

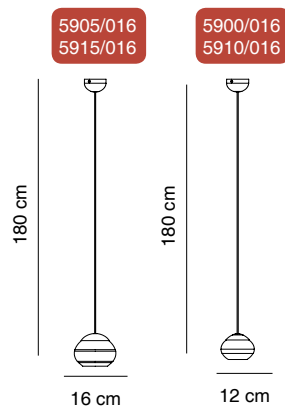
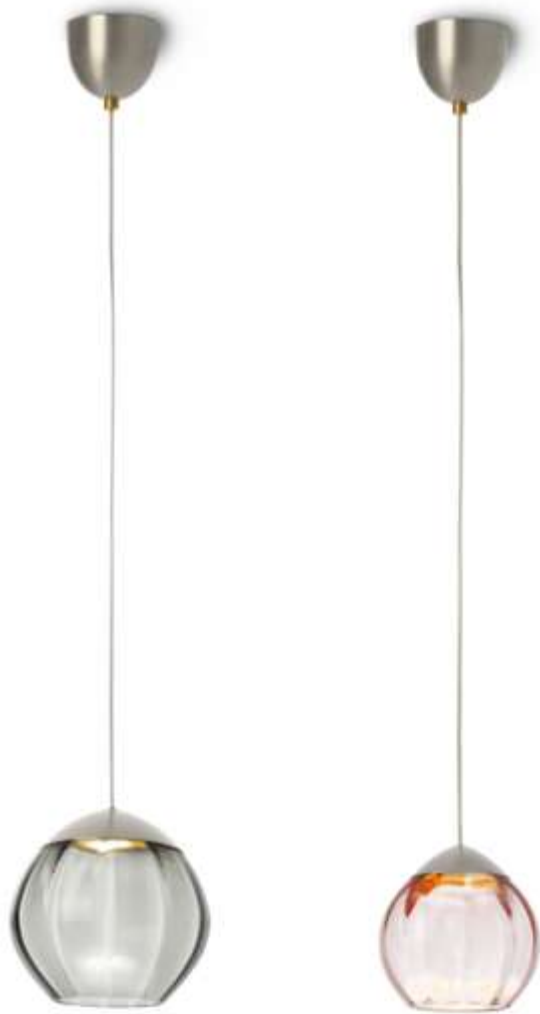

Soft

Design by Cristian Cubiñá

Pantalla cristal soplado rosado o negro
Shade blown glass pink or black

Estructura hierro níquel satinado.
Structure iron satin nickel

No regulable
Not dimmable

Led integrado
Integrated Led

5900/016 cristal pequeño rosado **small pink glass**

5905/016 cristal grande rosado **big pink glass**

5910/016 cristal pequeño negro **small black glass**

5915/016 cristal grande negro **big black glass**

LED Seoul 3W 372lm 2700K

CE IP 20



Soft

Design by Cristian Cubiñá

Pantalla cristal soplado rosado o negro
Shade blown glass pink or black

Estructura hierro níquel satinado.
Structure iron satin nickel

No regulable
Not dimmable

Led integrado
Integrated Led

5900/046 cristal rosado **pink glass**

5910/046 cristal negro **black glass**

LED Seoul 3W 372lm 2700K

CE IP 20

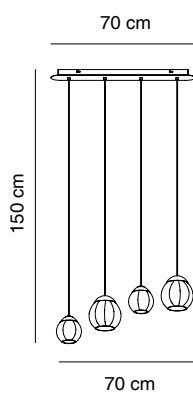







Soft

Design by Cristian Cubiñá

Pantalla cristal soplado rosado o negro
Shade blown glass pink or black

Estructura hierro níquel satinado.
Structure iron satin nickel

No regulable
Not dimmable

Led integrado
Integrated Led

5900/056 cristal rosado **pink glass**

5910/056 cristal negro **black glass**

LED Seoul 3W 372lm 2700K

CE IP 20

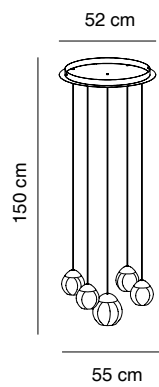





Moon

Design by Josep Novell & Ernest Perera

Pantalla Polietileno rotomoldeado opal
Shade white textured rotomolded polyethylene

Estructura hierro pintado blanco texturizado
Structure iron textured white painted

No regulable
Not dimmable

Led integrado
Integrated Led

5850/011

LED Epistar 40W 3250lm 3000K

CE IP 23

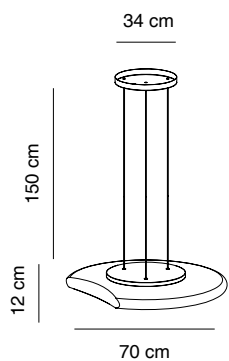





SuperMoon

Design by Josep Novell & Ernest Perera

Pantalla Polietileno rotomoldeado opal
Shade white textured rotomolded polyethylene

Estructura hierro pintado blanco texturizado
Structure iron textured white painted

No regulable
Not dimmable

Led integrado
Integrated Led

5860/041

4 x LED Epistar 40W 3250lm 3000K

CE IP 20

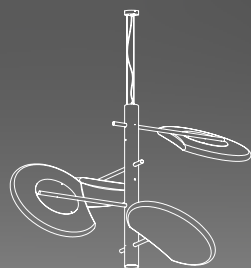

180 cm

200 cm



Deco

Design by Cristian Cubiñá

Pantalla cristal prensado de Bohemia en acabado transparente
Shade Pressed Bohemia crystal transparent glass

Estructura hierro
Structure iron

Lámpara no incluida
Lamp not included

5550/011 cromo **chome**

5530/011 dorado brillo **polished gold**

 G9 LED

CE  IP 20

13 cm

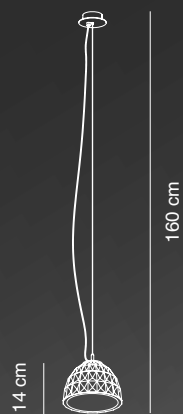

160 cm

14 cm

28 cm







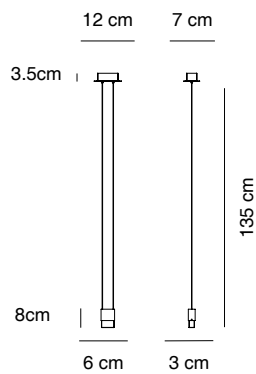

Led Box

Design by Cristian Cubiñá

Pantalla fundición aluminio pulido
Shade polished die cast aluminium

Cristal transparente arenado
Transparent sandblasted glass

Estructura de acero inoxidable pulido espejo
Structure mirror polished stainless steel

No regulable
Not dimmable

Led integrado
Integrated Led

5080/016

LED Citizen 3W 250lm 2700K

CE IP 20







Led Oval

Design by Cristian Cubiñá

Pantalla fundición aluminio pulido
Shade polished die cast aluminium

Estructura acero inoxidable pulido espejo
Structure mirror polished stainless steel

No regulable
Not dimmable

Led integrado
Integrated Led

5180/017 colgante individual **single pendant**

5180/047 colgante lineal 4 luces **linear pendant 4 lights**

LED Citizen 3W 250lm 2700K

CE IP 20

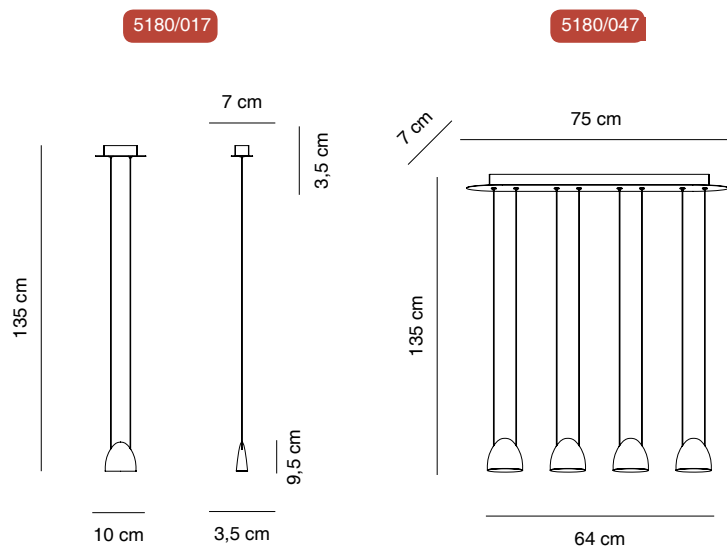
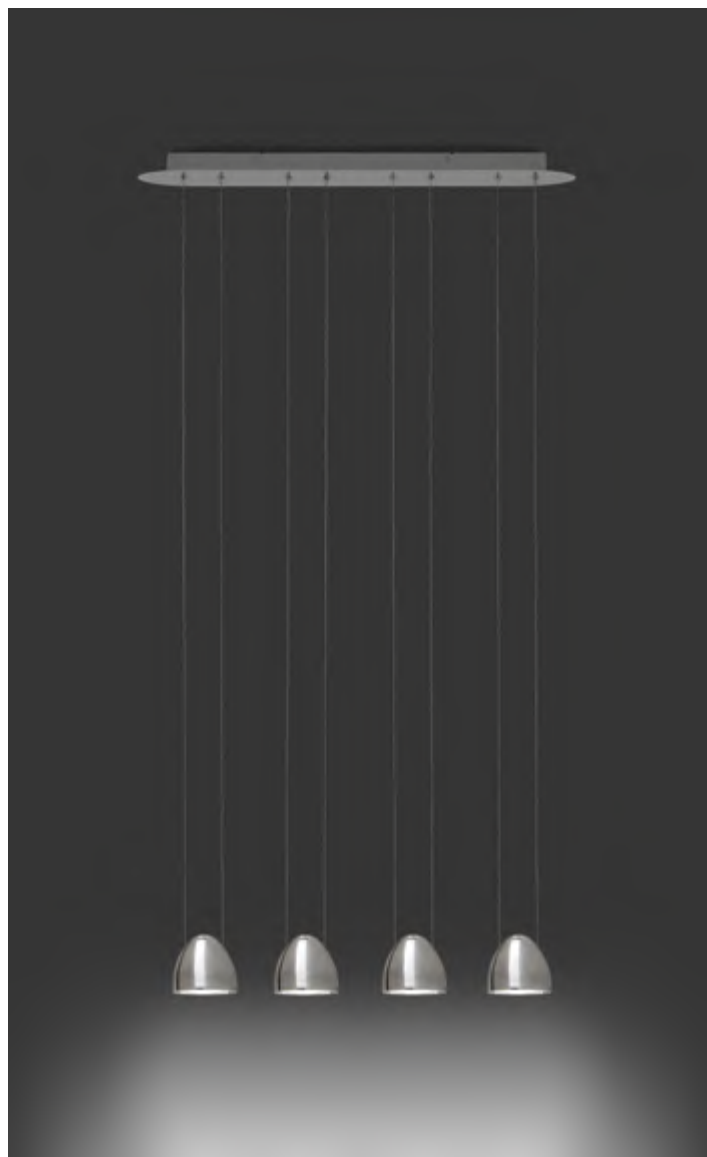

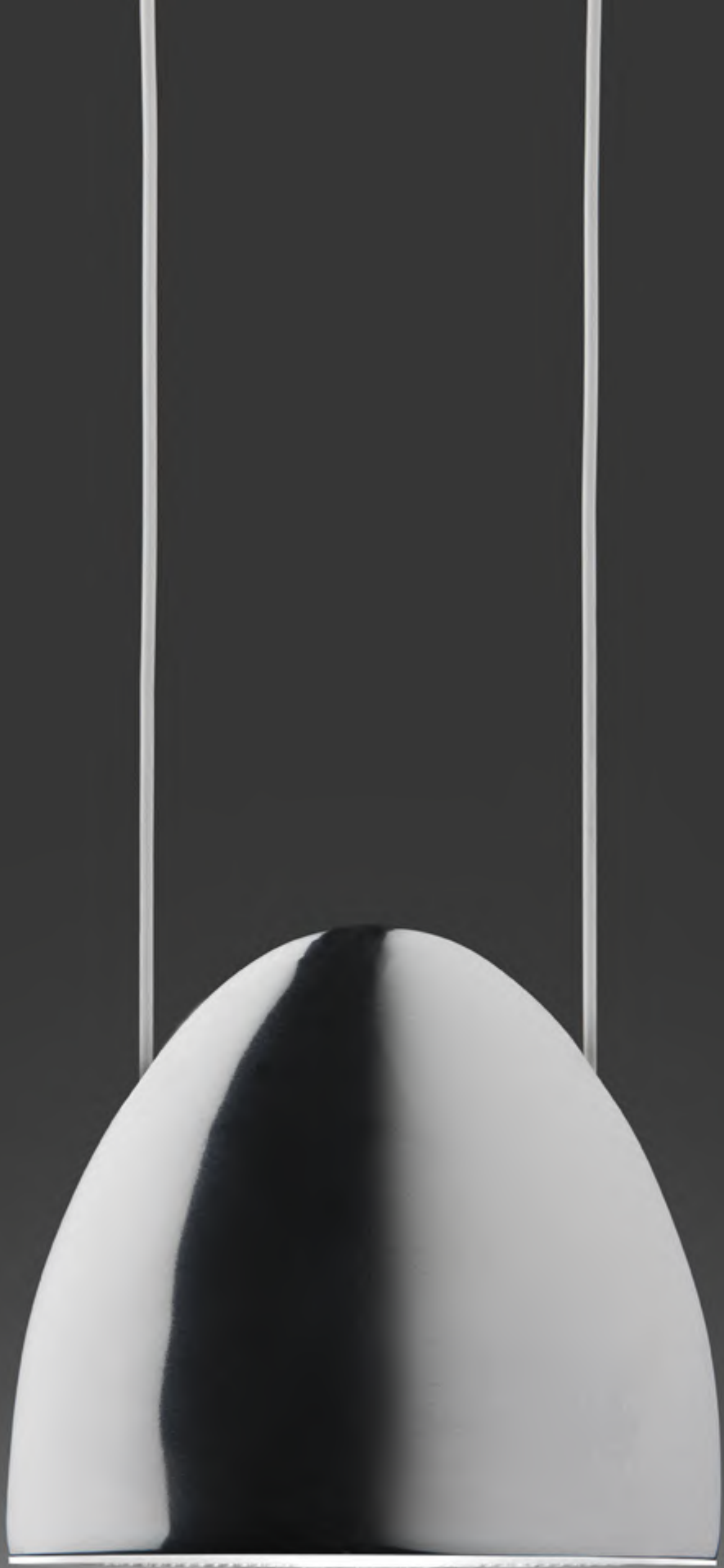





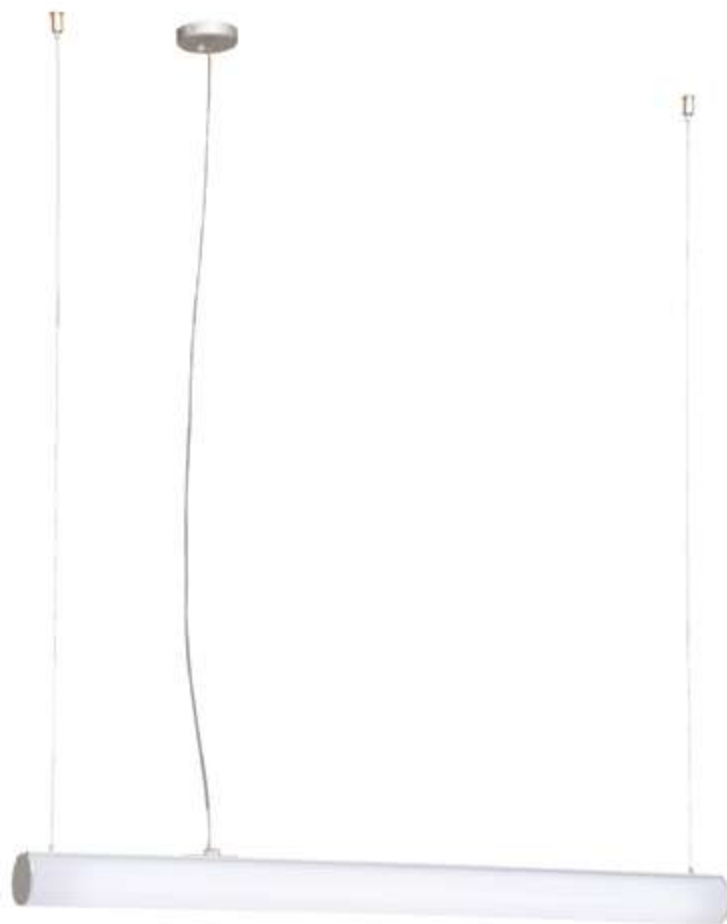

Bath A Led

Design by Oriol Llahona

Pantalla policarbonato opal
Shade opal polycarbonate

Estructura hierro pintado epoxi
Structure epoxy painted iron

Regulable mediante Triac
Dimmable byTriac

Led integrado
Lamp included

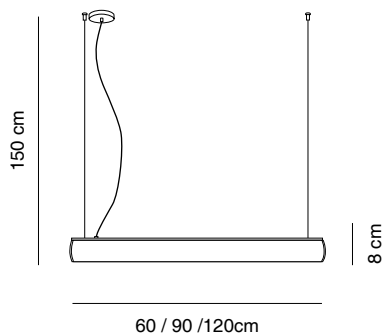

5420/061LED 60cm 14W 1350lm blanco mate **matt white**
5420/091LED 90cm 22W 2160lm blanco mate **matt white**
5420/121LED 120cm 30,8W 2970lm blanco mate **matt white**

5420/066LED 60cm 14W 1350lm plata **silver**
5420/096LED 90cm 22W 2160lm plata **silver**
5420/126LED 120cm 30,8W 2970lm plata **silver**

Led 3000K

CE IP 23











Lens Led

Design by Cristian Cubiná

Pantalla metacrilato opal
Shade opal methacrylate

Estructura hierro pintado epoxi blanco mate
Structure iron epoxi matt white painted

No Regulable
Not dimmable

Led integrado
Integrated Led

5290/011

LED Epistar 40W 3250lm 3000K

CE IP 20

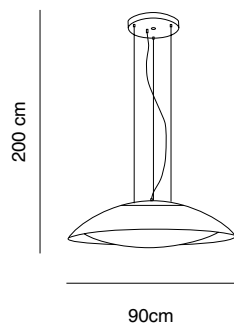

200 cm

90cm



Stone Led

Design by Josep Puig & Josep Novell

Pantalla polietileno rotomoldeado
Shade rotomolded polyethylene

Estructura hierro pintado epoxi blanco mate
Structure epoxy matt white painted iron

No Regulable
Not dimmable

Led integrado
Integrated Led

5300/036

LED Epistar 40W 3250lm 3000K

CE IP 20

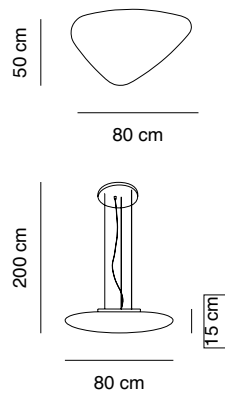





Al subir y bajar el aro de silicona conseguimos variar la forma de luminaria.



By pulling up or down the silicon ring we can modify the external outfit of the luminaire.

Drop Led

Design by Cristian Cubiñá

Pantalla cristal borosilicato transparente
Shade borosilicate transparent glass

Estructura hierro cromado
Structure chrome iron

Cables pueden acortarse máx 60cm
Cables can be shortened max. 60cm

Lámparas Led incluidas, reemplazables, no regulables
Led lamps included, replaceable, not dimmable

Estructura normal largo max.170 - min.110cm

Normal structure length max.170 - min.110cm

5110/196LED G4 19x1,1W 95lm 2700K CRI>80

5110/376LED G4 37x1,1W 95lm 2700K CRI>80

Estructura especial largo 70cm

Special structure length 70cm

5110/196S LED G4 19x1,1W 95lm 2700K CRI>80

5110/376S LED G4 37x1,1W 95lm 2700K CRI>80

Estructura especial largo max.350 - min.290cm

Special structure length max.350 - min.290cm

5110/196XL LED G4 19x1,1W 95lm 2700K CRI>80

5110/376XL LED G4 37x1,1W 95lm 2700K CRI>80

5110/196

16 cm

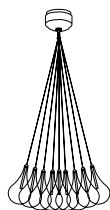

Ø 60 cm

5110/376

20 cm

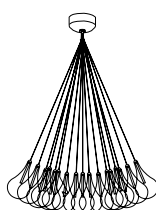

Ø 80 cm

CE IP 20





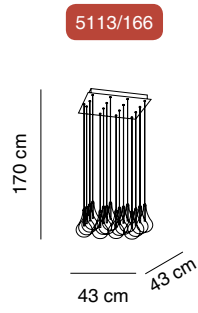
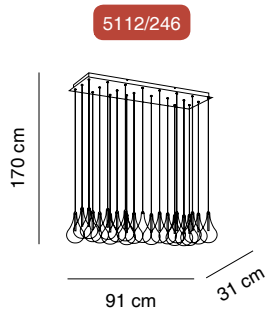

Drop Led

Design by Cristian Cubiñá

Pantalla cristal borosilicato transparente
Shade borosilicate transparent glass

Estructura hierro
Structure iron

Lámparas Led incluidas, reemplazables, no regulables
Led lamps included, replaceable, not dimmable

5112/246LED G4 24x1,1W 95lm 2700K CRI>80

5113/166LED G4 16x1,1W 95lm 2700K CRI>80

CE IP 20





Drop Led

Design by Cristian Cubiñá

Pantalla cristal borosilicato transparente
Shade borosilicate transparent glass

Estructura hierro cromado
Structure chromed iron

Lámpara Led incluida, reemplazable, no regulable
Led lamp included, replaceable, not dimmable

5111/016LED

 G4 Led 1,1W 95lm 2700K CRI>80

CE 

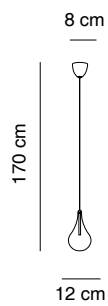

Plafones

Ceiling Lamps

Bath A Led / Deco / Drop S Led / Drop Downlight / Lens / Mizu / Moon / Stone
/ SuperMoon / Tribeca





Tribeca Downlight

Design Jordi LLopis

Pantalla alabastro
Shade alabaster

Estructura hierro pintado negro texturizado
Structure black textured painted iron

Driver incluido. **Driver included**

Led integrado
Integrated led

No regulable **Not dimmable**

9800/018

Regulable mediante Triac **Dimmable by Triac**

9800/018RG

LED Seoul 4,5W 270lm 2700K

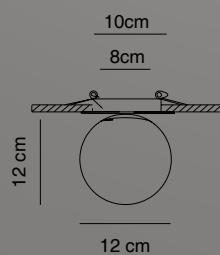

CE IP 20







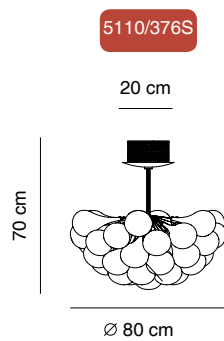
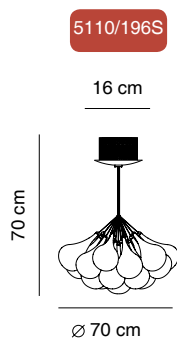

Drop S Led

Design by Cristian Cubiñá

Pantalla cristal borosilicato transparente
Shade borosilicate transparent glass

Estructura hierro cromado / **Structure chromed iron**

Lámparas Led incluidas, reemplazables, no regulables
Led lamps included, replaceable, not dimmable

5110/196S LED 19x G4 1,1W 95lm 2700K CRI>80

5110/376S LED 37x G4 1,1W 95lm 2700K CRI>80

CE IP 20



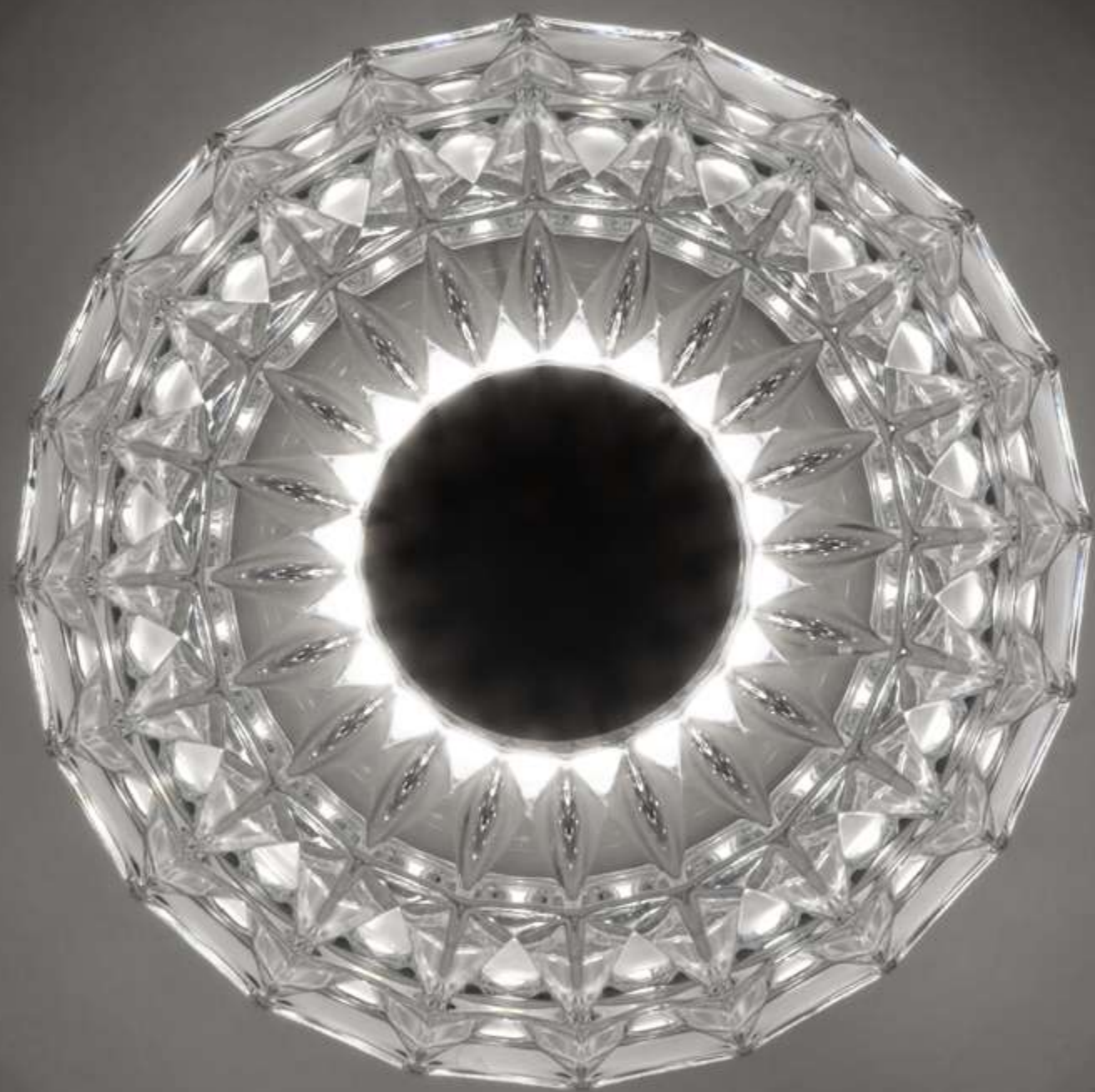



Deco

Design by Cristian Cubiñá

Pantalla cristal prensado de Bohemia en acabado transparente
Shade pressed Bohemia crystal transparent glass

Estructura hierro
Structure iron

Lámpara no incluida **Lamp not included**

9550/011 Cromo **Chrome**

9530/011 Dorado **Gold**

 E14 LED

CE  IP 20

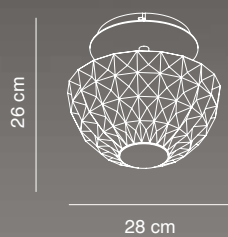







Moon

Design by Josep Novell & Ernest Perera

Pantalla polietileno rotomoldeado texturizado
Shade rotomolded polyethylene textured

Estructura hierro pintado blanco texturizado
Structure iron textured white

No regulable
Not dimmable

Led integrado
Integrated Led

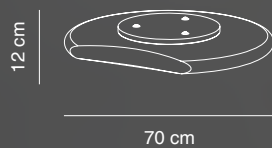

9850/011

LED Epistar 40W 3250lm 3000K

CE  







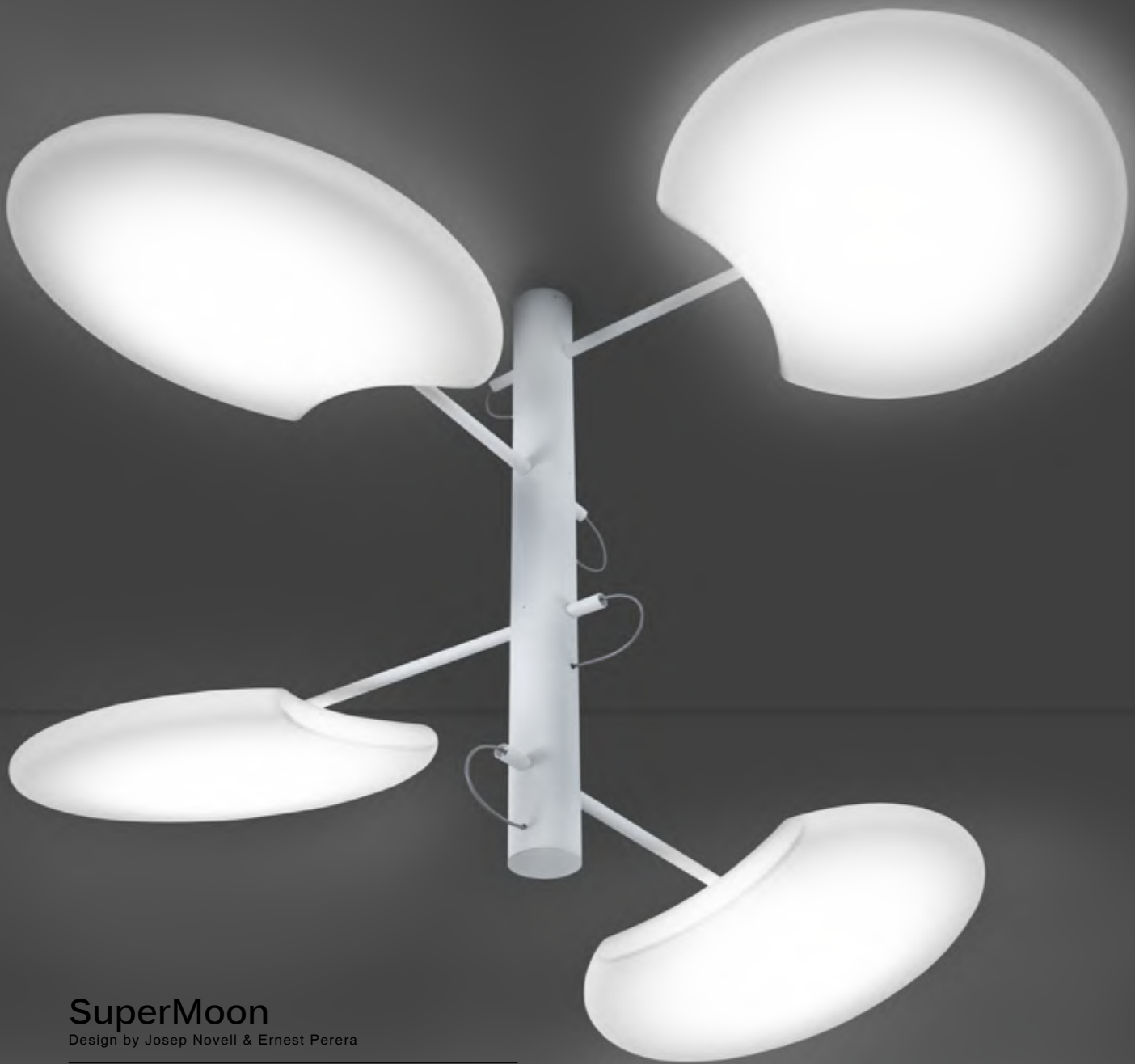

SuperMoon

Design by Josep Novell & Ernest Perera

Pantalla polietileno rotomoldeado texturizado
Shade rotomolded polyethylene textured

Estructura hierro pintado blanco texturizado
Structure iron textured white

No regulable
Not dimmable

Led integrado
Integrated Led

9860/041

4 x LED Epistar 40W 3250lm 3000K

CE  

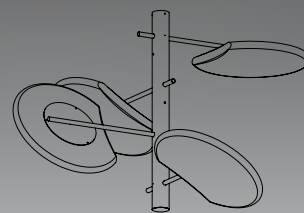

128 cm

200 cm







Stone Led

Design by Josep Novell & Josep Puig

Pantalla polietileno rotomoldeado
Shade rotomolded polyethylene

Estructura hierro pintado epoxi blanco mate
Structure epoxy matt white painted iron

No regulable **Not dimmable.**

Led integrado
Integrated Led

9300/036

LED Epistar 40W 3250lm 3000K

CE  

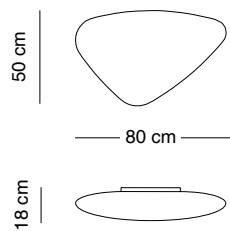

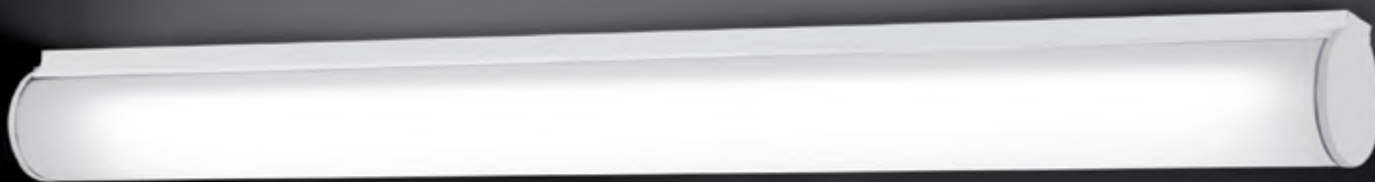

Bath A Led

Design by Oriol Llahona

Pantalla policarbonato opal
Shade opal policarbonate

Estructura hierro pintado epoxi
Structure epoxy painted iron

Regulable mediante Triac
Dimmable by Triac

Led integrado
Integrated Led

4420/061LED 14W 1350lm 60 cm blanco mate **matt white**
4420/091LED 22W 2160lm 90 cm blanco mate **matt white**
4420/121LED 30,8W 2970lm 120 cm blanco mate **matt white**

4420/066LED 14W 1350lm 60 cm plata **silver**
4420/096LED 22W 2160lm 90 cm plata **silver**
4420/126LED 30,8W 2970lm 120 cm plata **silver**

Led 3000K

CE IP 23



60cm
90 cm
120 cm





Mizu

Design by Ricard Ferrer

Pantalla cristal triplex opal
Shade opal blown glass

Estructura hierro pintado epoxi
Structure iron epoxy painted

Lámpara no incluida
Lamp not included

9282/011 blanco mate **matt white**

9282/016 plata **silver**

9283/011 blanco mate **matt white**

9283/016 plata **silver**

9281/011 blanco mate **matt white**

9281/016 plata **silver**

 G9 LED

CE  

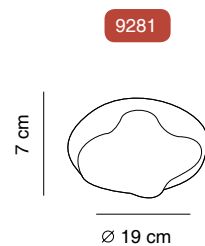
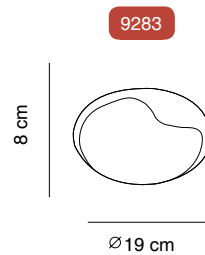
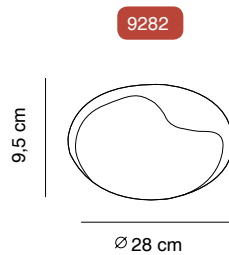

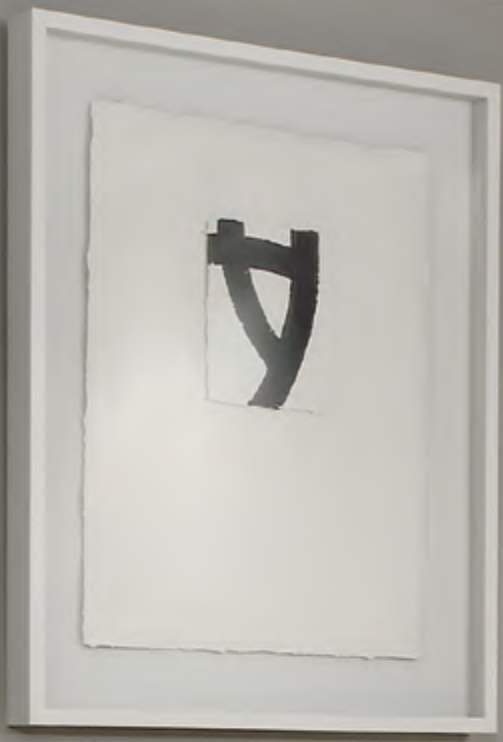





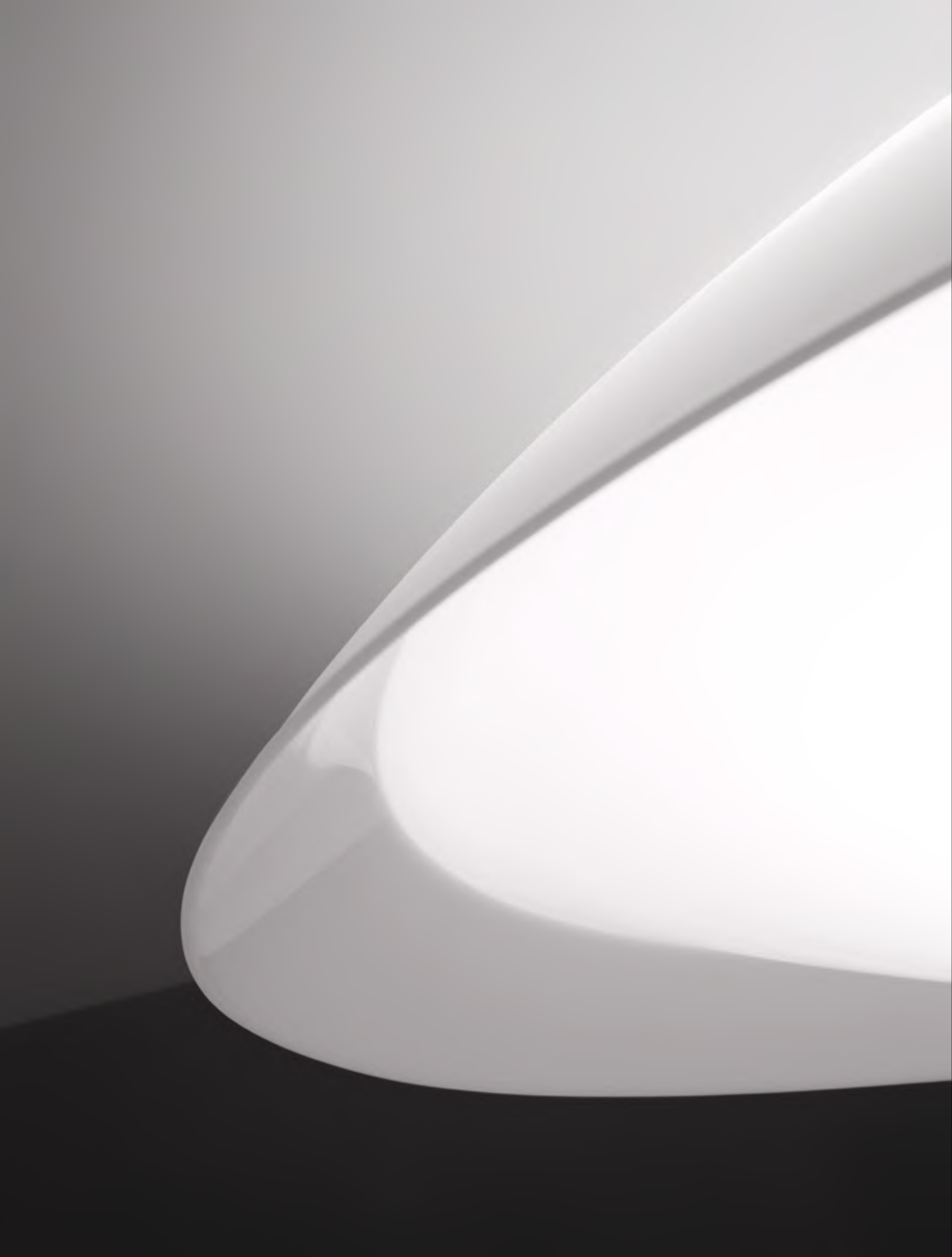



Lens Led

Design by Cristian Cubin

Pantalla de metacrilato blanco
Shade opal methacrylate

Estructura hierro pintado epoxi blanco mate
Structure white epoxy painted iron

No regulable
Not dimmable

Led integrado
Integrated Led

9290/011

LED Epistar 40W 3250lm 3000K

CE  

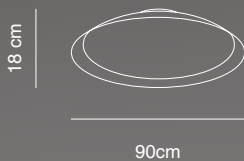



Drop Downlight Led

Design Cristian Cubiñá

Pantalla cristal borosilicato transparente
Shade borosilicate transparent glass

Foco empotrado. Estructura hierro cromado
Embedded downlight. Structure chromed iron

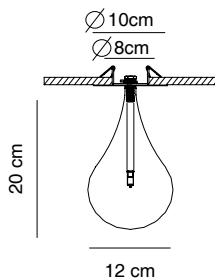

Driver incluido
Driver included

Lámpara incluida, no regulable y reemplazable
Lamp included, not dimmable and replaceable



9111/016 LED

 LED G4 1,1W 95lm 2700K CRI>80

CE  



Apliques

Wall Lamps

Bath A Led / Finger / Flat Led / Hotel / Madame / MiniFlat / MiniSpot / Mizu /
Paros Alabaster / Tribeca





MiniSpot

Design by Cristian Cubiñá

Estructura hierro pintado texturizado
Structure iron textured painted

No Regulable. Incluye interruptor On-Off
Not dimmable. Switch included On-Off

Led integrado **Integrated Led**

4525/011 blanco **white**

4525/018 negro **black**

LED Cree 3W 260lm 3000K CRI>90

CE IP 20

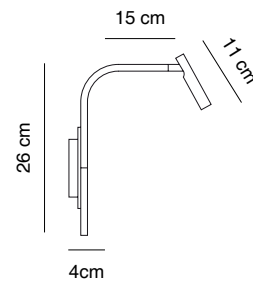





TheLight

Design by Cristian Cubiñá

Estructura hierro
Structure iron

Pantalla metacrilato arenado
Shade sandblasted methacrylate

No regulable. Versión regulable: constatar
Not dimmable. Dimmable version: please contact us

Led integrado. **Integrated Led.**

4150/031 blanco mate **matt white**

4150/038 negro mate **matt black**

4150/036 níquel satinado **satin nickel**

4150/030 dorado satinado **satin gold**

LED Cree 11,10W 624,25lm 2700K CRI>80

CE IP 20

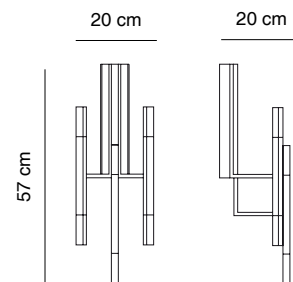







Finger

Design by Cristian Cubiña

Estructura hierro pintado texturizado

Structure textured epoxy painted iron

Con interruptor **With switch**

Lámpara incluida, reemplazable, no regulable

Lamp included, replaceable, not dimmable

4020/011 blanco texturizado **textured white**

4020/012 corten texturizado **textured corten**

4020/018 negro texturizado **textured black**

G4 LED 1,1W 95lm 2700K CRI>80

CE IP 20

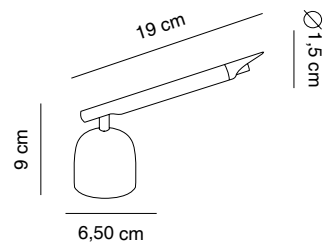

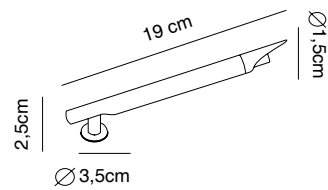

Finger

Design by Cristian Cubiña

Estructura hierro pintado texturizado
Structure textured epoxy painted iron

Sin interruptor **Without switch**

Lámpara incluida, reemplazable, no regulable
Lamp included, replaceable, not dimmable

4021/011 blanco **white**
4021/012 corten **corten**
4021/018 negro **black**

G4 LED 1,1W 95lm 2700K CRI>80

CE IP 20







Tribeca

Design by Jordi LLopis

Pantalla alabastro
Shade alabaster

Estructura hierro pintado negro texturizado
Structure textured black painted iron

Interruptor para el lector **Switch for the reading light**

Led integrado
Integrated Led

No regulable **Not dimmable**

4800/028 un interruptor **one switch**

Regulable mediante Ttriac **Dimmable by Triac**

4800/028RG un interruptor **one switch**

LED Seoul 4.5W 270lm 2700K

LED Cree 3W 260lm 30° 3000K

CE IP 20

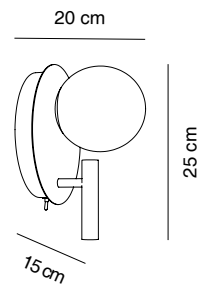



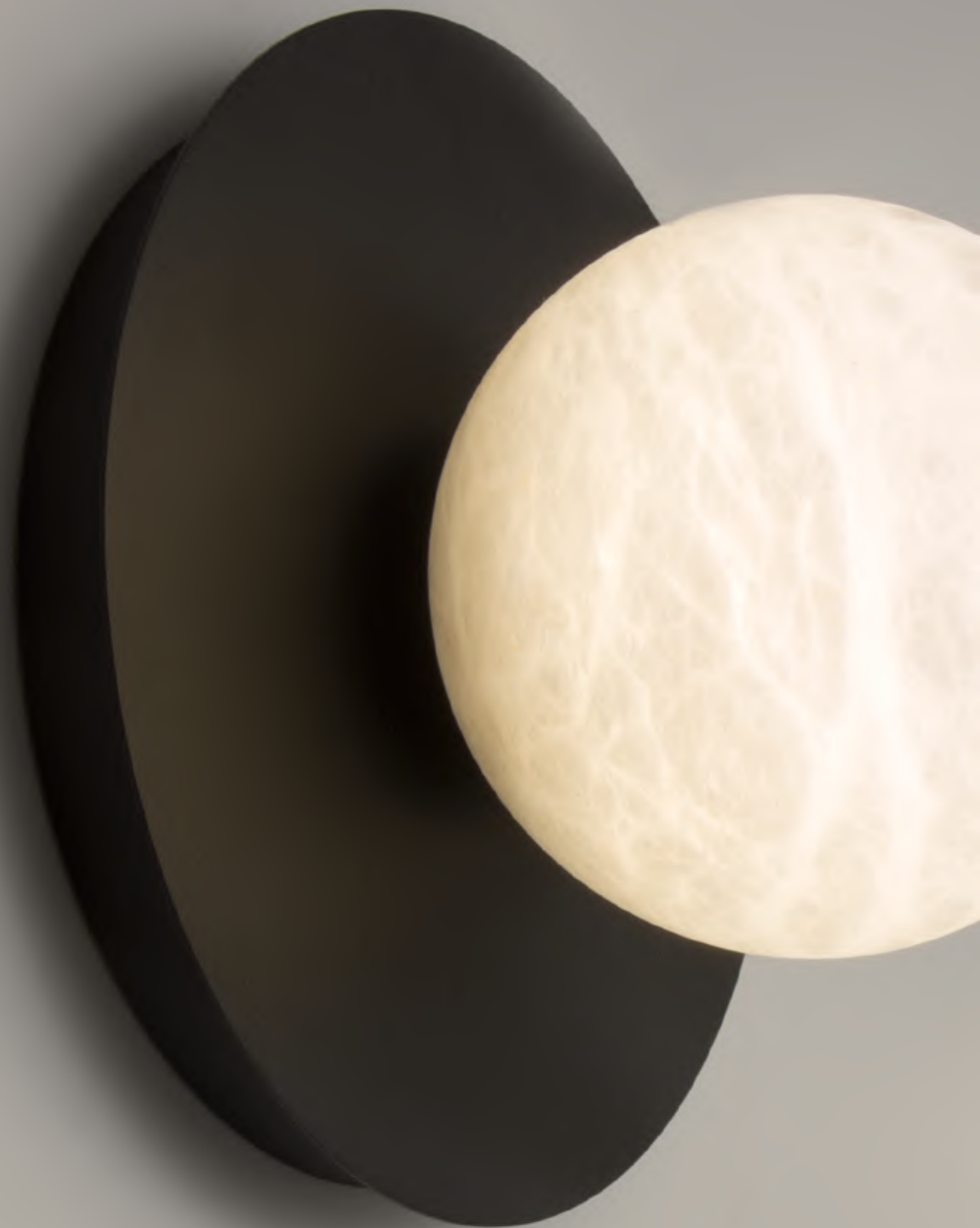





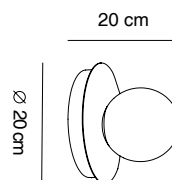

Tribeca

Design by Jordi LLopis

Pantalla alabastro
Shade alabaster

Estructura hierro pintado negro texturizado
Structure black textured epoxy painted iron

Led integrado
Integrated Led

No regulable **Not dimmable**

4800/018

Regulable **mediante Triac Dimmable by Triac**

4800/018RG

LED Seoul 4.5W 270lm 2700K

CE IP 20



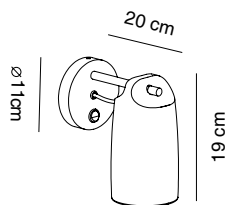

Paros Alabaster

Design by Josep Novell & Ernest Perera

Pantalla **alabastro**
Shade alabaster

Estructura hierro pintado blanco texturizado
Structure textured white painted iron

Con interruptor With switch

Lámpara no incluida, reemplazable
Lamp not included, replaceable

4270/011

 E14 LED

CE  



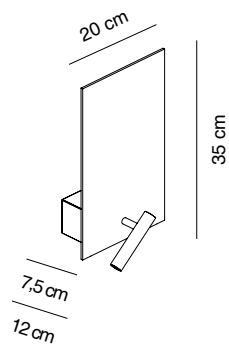

Flat Led

Design by Josep Novell & Ernest Perera

Estructura hierro
Structure iron

Con interruptor para el lector o dos interruptores
With switch for the reading light or two switches

Led integrado en el lector
Integrated LED included for the reading light

4416/011 blanco mate, un interruptor **matt white, one switch**

4416/018 negro mate, un interruptor **matt black, one switch**

4416/211 blanco mate, un interruptor **matt white, two switch**

4416/218 negro mate, un interruptor **matt black, two switch**

 E27 LED

LED Cree 3W 260lm 30° 3000K

CE 







MiniFlat

Design by Cristian Cubiñá

Estructura hierro
Structure iron

No regulable
Not dimmable

Led integrado
Integrated Led

4419/011 blanco texturizado **textured white**

4419/018 negro texturizado **textured black**

4419/016 níquel satinado **satín nickel**

4413/011 blanco texturizado **textured white**

4413/018 negro texturizado **textured black**

4413/016 níquel satinado **satín nickel**

4414/011 blanco texturizado **textured white**

4414/018 negro texturizado **textured black**

4414/016 níquel satinado **satín nickel**

LED Cree 3W 260lm 30° 3000K

CE IP 20

4419

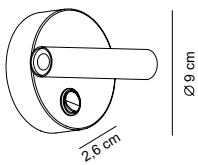

4414

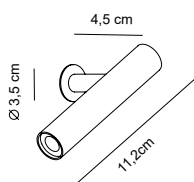

4413

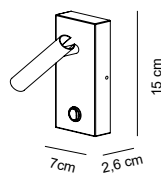

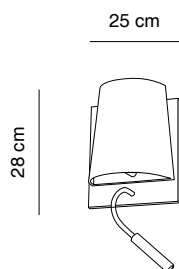

Hotel

Design by Cristian Cubiñá

Pantalla algodón negra
Shade black cotton

Estructura hierro pintado epoxi champagne
Structure epoxi champagne painted iron

Con interruptor para el lector
With switch for the reading light

Led integrado
Integrated Led

4540/018

 E27 LED

LED 3W 30° 4000K

CE IP 20





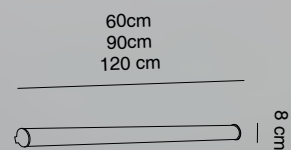

Bath A Led

Design by Oriol Llahona

Pantalla policarbonato opal
Shade opal polycarbonate

Estructura hierro pintado epoxi
Structure epoxy painted iron

Regulable mediante Triac
Dimmable through Triac

Led integrado,
Integrated Led

-
- | | | | | | |
|-------------|-------|--------|--------|-------------|--------------------------|
| 4420/061LED | 14W | 1350lm | 60 cm | blanco mate | <i>matt white</i> |
| 4420/091LED | 22W | 2160lm | 90 cm | blanco mate | <i>matt white</i> |
| 4420/121LED | 30,8W | 2970lm | 120 cm | blanco mate | <i>matt white</i> |
| 4420/066LED | 14W | 1350lm | 60 cm | plata | <i>silver</i> |
| 4420/096LED | 22W | 2160lm | 90 cm | plata | <i>silver</i> |
| 4420/126LED | 30,8W | 2970lm | 120 cm | plata | <i>silver</i> |

Led 3000K

CE IP 23



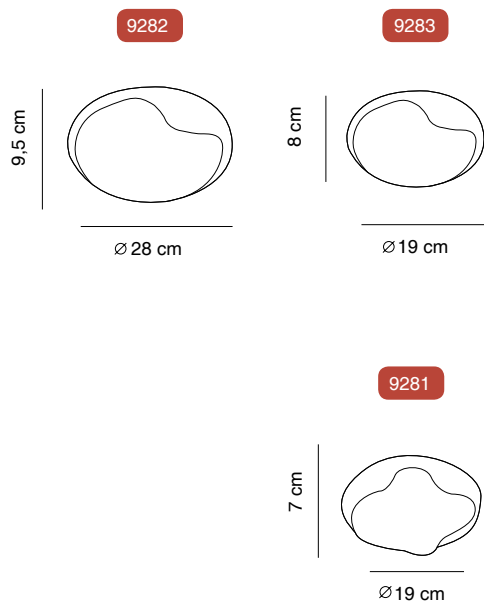

Mizu

Design by Ricard Ferrer

Pantalla cristal triplex opal
Shade opal blown glass

Estructura hierro pintado epoxi
Structure iron epoxy painted

Lámpara no incluida
Lamp not included

9282/011 blanco mate **matt white**

9282/016 plata **silver**

9283/011 blanco mate **matt white**

9283/016 plata **silver**

9281/011 blanco mate **matt white**

9281/016 plata **silver**

 G9 LED

CE  IP 23











Madame

Design by Oriol Llahona

Estructura hierro pintado epoxi
Structure iron epoxi painted

Con interruptor
With switch

Lámpara no incluida
Lamp not included

4650/016 blanco mate plata **mat white silver**

4650/018 negro mate dorado **mat black gold**

 G9 LED

CE  

4650/016 4650/018

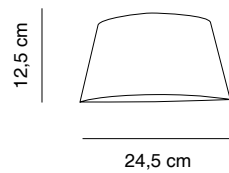

Exterior Outdoor

Stone Out Led / Tiny







Tiny

Design by Jose Novell & Josep Puig

Estructura latón acabado níquel satinado
Structure brass satin nickel finished

Pantalla polietileno rotomoldeado / Lámpara no incluida
Shade rotomolded polyethylene/Lamp not included

4370/016

4371/016

4372/016

 E27 LED

CE  

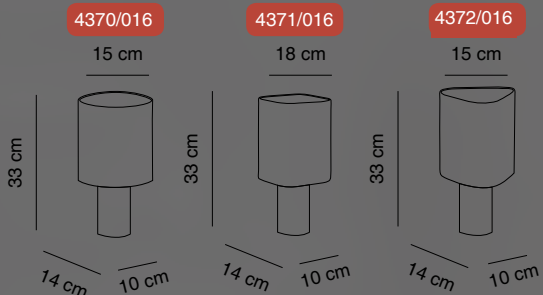

Tiny

Design by Josep Novell & Josep Puig

Estructura latón acabado níquel satinado
Structure brass satin nickel finished

Pantalla polietileno rotomoldeado / Lámpara no incluida
Shade rotomolded polyethylene/Lamp not included

2370/016

2371/016

2372/016

 E27 LED

CE  

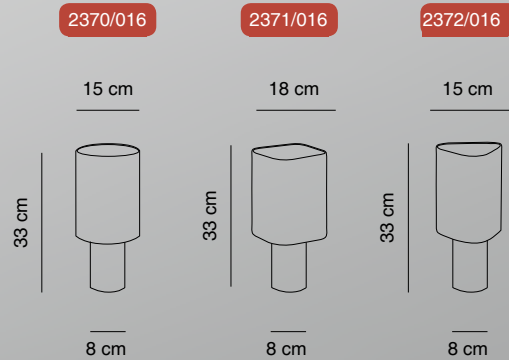

Tiny

Design by Josep Novell & Josep Puig

Estructura latón acabado níquel satinado
Structure brass satin nickel finished

Con 4mt cable con funda de neopreno y clavija Schuko
Structure With 4mt neoprene cable with Shucko plug

Lámpara no incluida
Lamp not included

2375/016

2376/016

2377/016

 E27 LED

CE   IP45

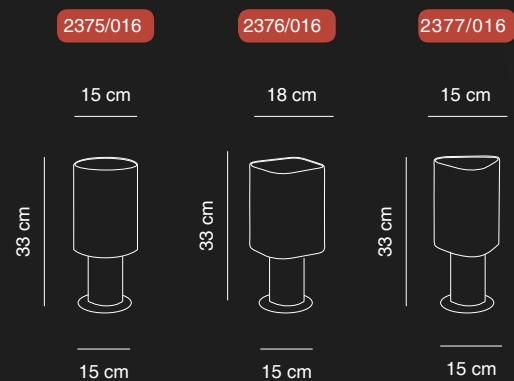



Stone Out Led

Design by Josep Puig & Josep Novell

Pantalla polietileno rotomoldeado
Shade rotomolded polyethylene

Estructura acero inoxidable pintado blanco mate
Structure matt white panted stainless steel

No regulable
Not dimmable

Led integrado
Integrated Led

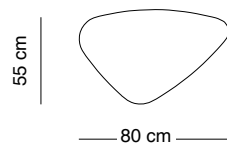

9330/036

LED Epistar 40W 3250lm 3000K

CE  







Stone Out Led

Design by Josep Puig & Josep Novell

Pantalla polietileno rotomoldeado
Shade rotomolded polyethylene

Estructura acero inoxidable pulido/aluminio
Structure polished stainless steel/aluminium

No regulable
Not dimmable

Led integrado
Integrated Led

4 metros de cable con funda de neopreno y clavija Schuko
4 meters of neoprene cable with Schuko plug

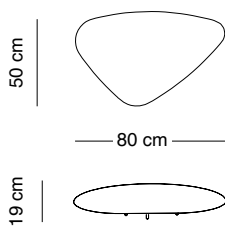

2300/036

LED Epistar 40W 3250lm 3000K

CE  

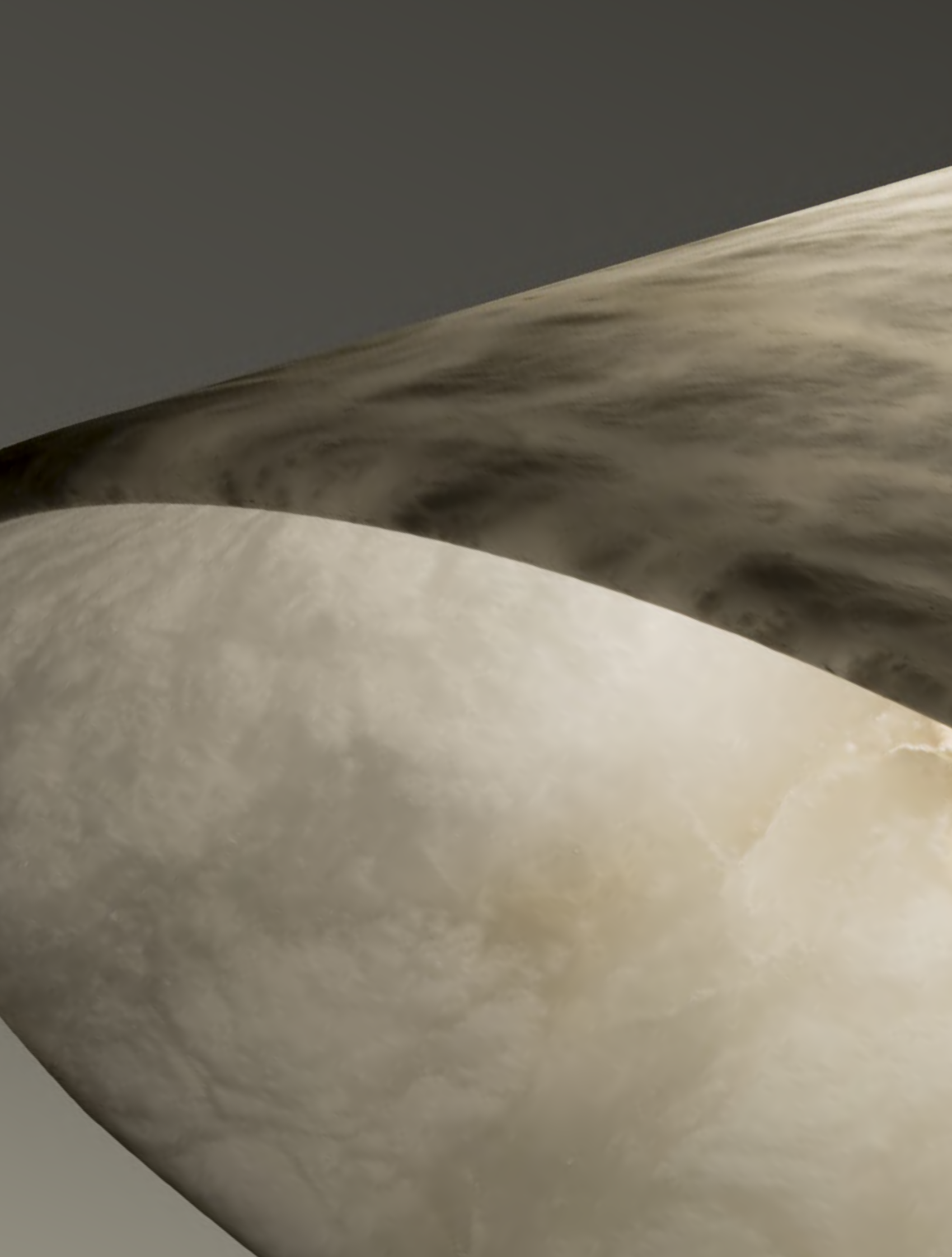

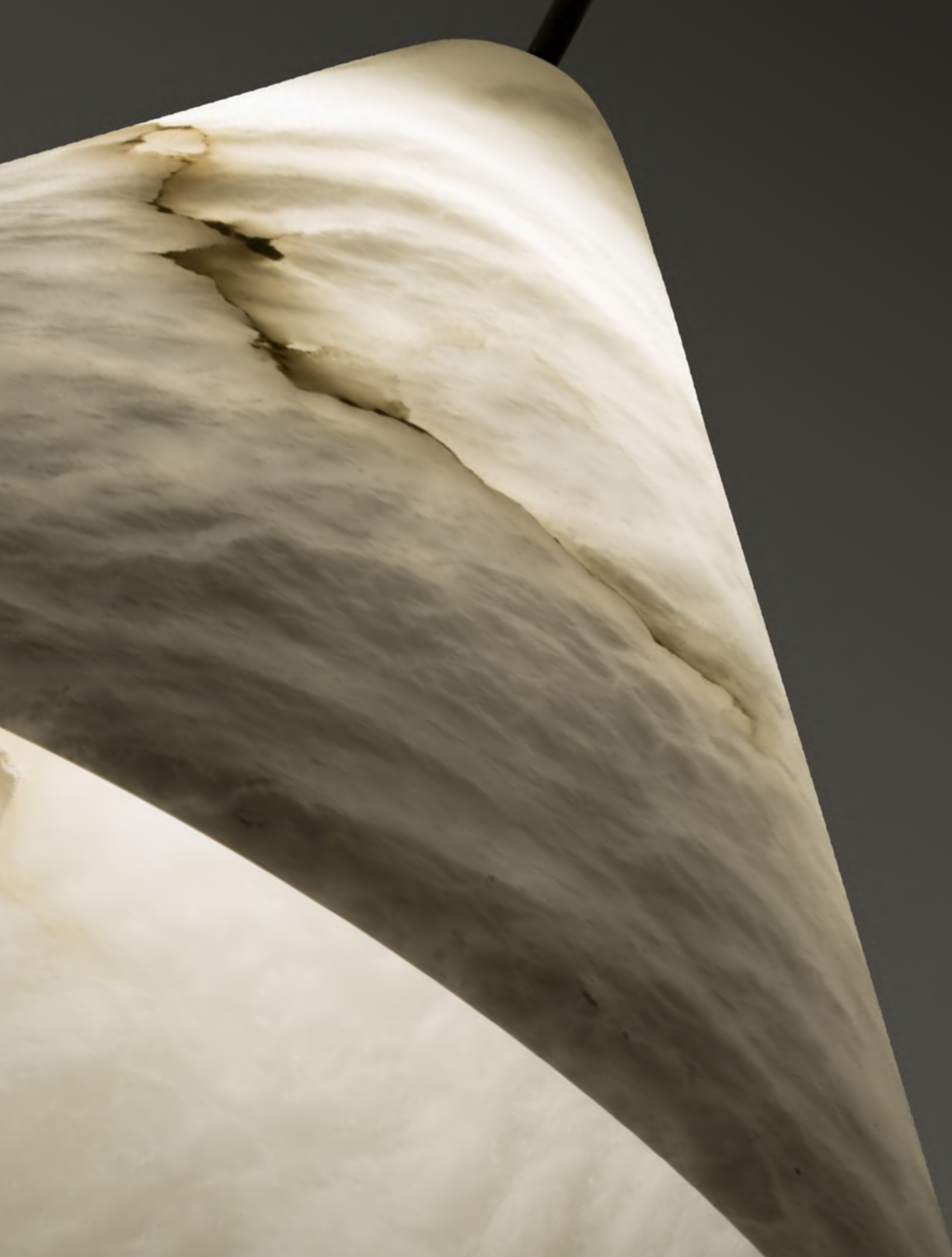

Pintura / *Painted*

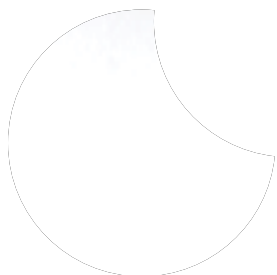

blanco mate
matt white

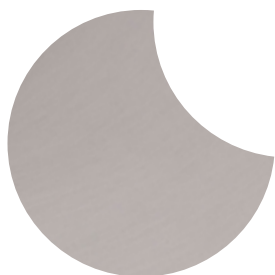

plata
silver

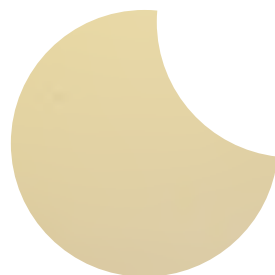

champagne
champagne

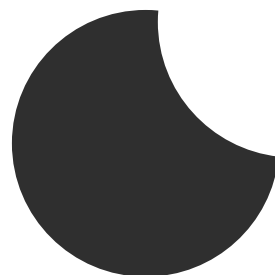

negro mate
matt black

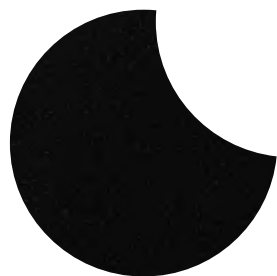

negro texturizado
textured black



corten texturizado
textured corten

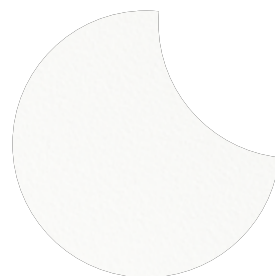

blanco texturizado
textured white

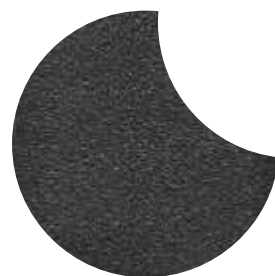

antracita texturizado
textured anthracite

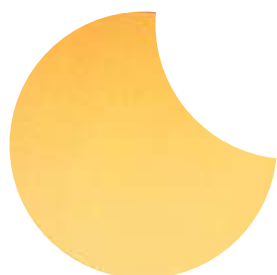

dorado *mate*
matt gold



negro brillante
glossy black

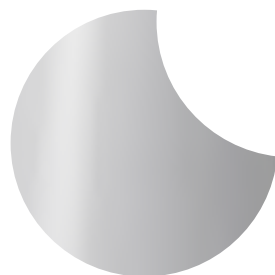

blanco brillante
glossy white

Cristal / *Glass*



transparente Deco
transparent Deco



negro Soft
black Soft



rosa Soft
pink Soft



opal
opal



borosilicato estriado
fluted borosilicate



borosilicato transparente
transparent borosilicate

Baño electrolítico / **Electroplated**



dorado satinado
satin gold

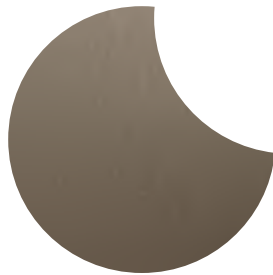

níquel satinado
satin nickel



bronce satinado
satin bronze

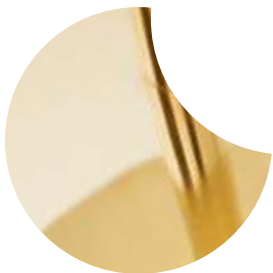

latón pulido brillo
polished brass

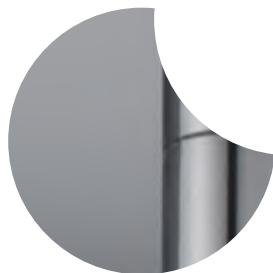

romo
chrome



dorado brillo
polished gold

Anodizado / **Anodized**

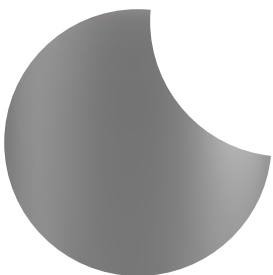

plata mate
matt silver

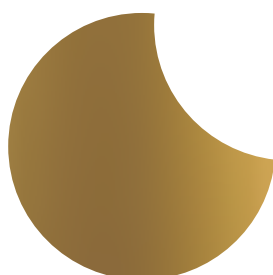

dorado mate
matt gold



latón arenado
sandblasted brass

Pantallas de tela / **Textile shades**

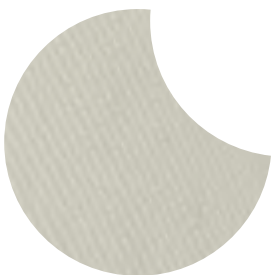

polipropileno
polypropylene

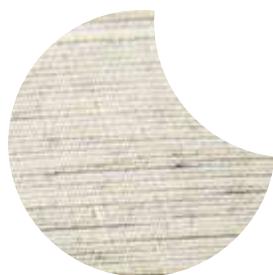

almadén plata
silver almaden



algodón negro
black cotton

Otros Materiales / **Other materials**



polietileno rotomoldeado
rotomolded polyethylene

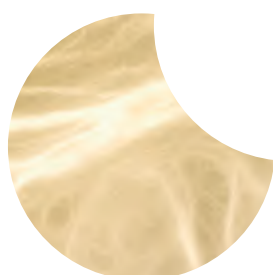

alabastro
alabaster



metacrilato opal
opal methacrylate



madera de Iroco
iroco wood

ALMA light
Barcelona





ALMA LIGHT se reserva el derecho a realizar modificaciones de producto sin previo aviso.
Catálogo realizado con papel ecológico, recíclelo, gracias

***ALMA LIGHT reserves the right to modify the products without prior notice.
Catalogue printed with ecological paper, please recycle it***

Fotografía / **Photography**

Tribeca USB

Cristina Gual Busqué,  Racó19, Sant Vicenç de Montalt (Spain)

Andrea Elballe & Pau Larrea,  La Rania, Vidrà (Spain)

Totem I, Tribeca, Star

 Cubiña, Barcelona (Spain)

 Curvas fotométricas disponibles en www.almalight.com
Photometric curves available on www.almalight.com

Para acabados / colores distintos de los artículos catalogados, diseños especiales o formatos customizados, contactar con ALMA LIGHT
For finishes/colors different from the ones on this catalog, special designs or customized formats, please contact ALMA LIGHT

ALMIGHT

Oficina central y almacén
Head office and warehouse

Cristobal de Moura 195-197
08019 Barcelona [Spain]

T [+34] 933 085 346
T [+34] 932 660 775
info@almalight.com

Follow us in Facebook
Instagram & Pinterest
@almalightbarcelona

www.almalight.com

