

hoyer

barcelona lights

New products 2017

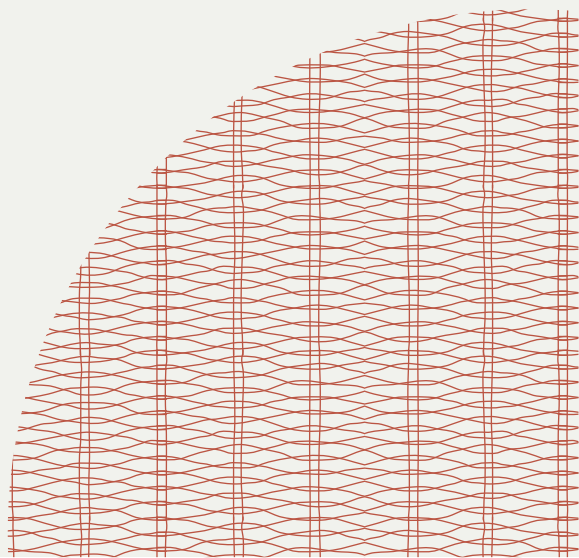
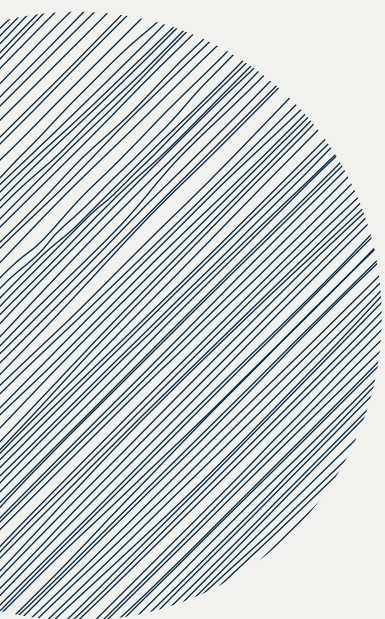

Atticus 3

Cornet 13

Drop 25

Drip 41

Marietta Outdoor 51

Moai 59

Penta 67

Tibeta 79

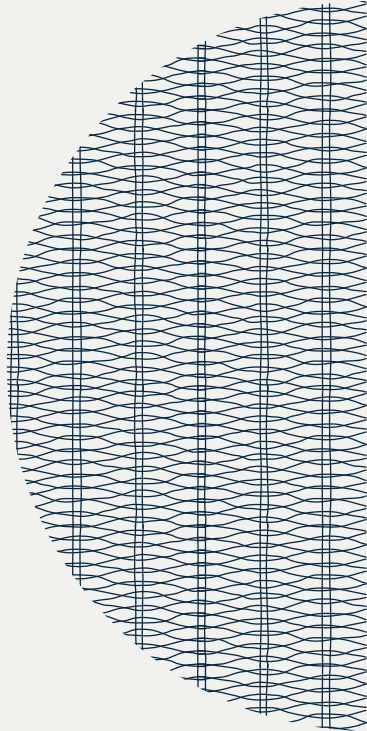
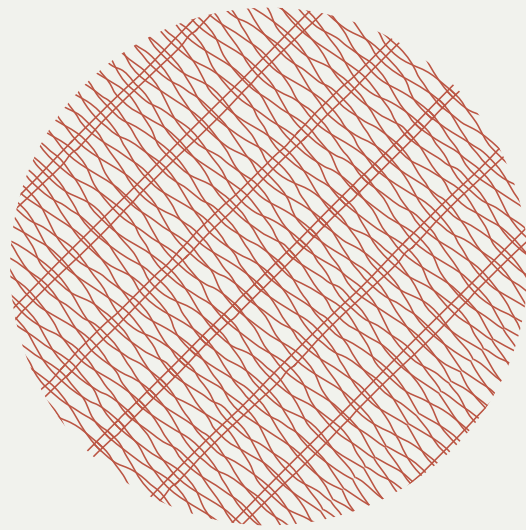
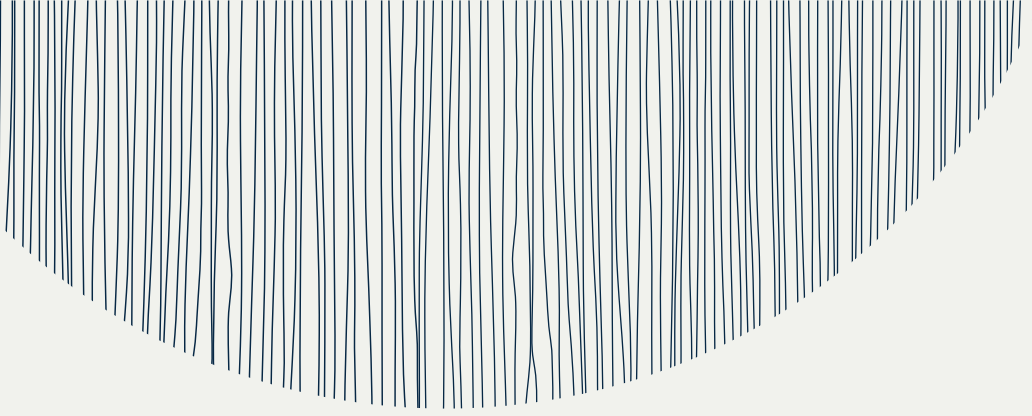

Atticus

by Joana Bover

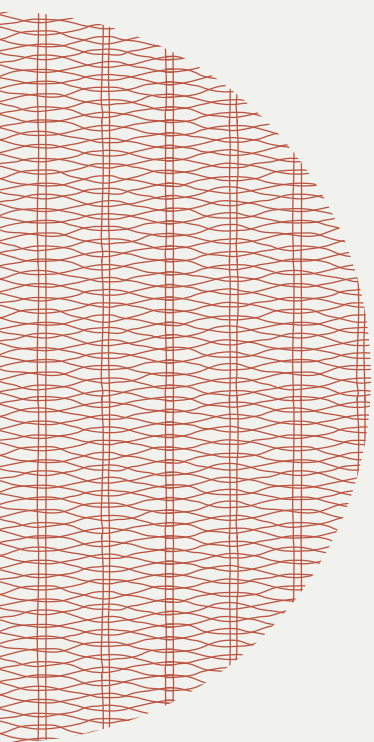

“Hay que estar bien. Estés donde estés, pero bien. Atticus es una lámpara que acoge y acompaña”.

“We must feel good. Wherever we are, really good. Atticus is a lamp that welcomes and accompanies”.



Joana Bover

Atticus es una lámpara que hace que cualquier momento y espacio sean más atractivos.

Ligera y sencilla en su diseño, pero sofisticada en las posibilidades que ofrece desde su discreta personalidad.

“A mí me gustan las lámparas que no molestan”, dice Joana. Atticus está siempre ahí, creando atmósfera, envolviendo, pero sin apenas ocupar espacio en superficie.

Estética y sencillez, pero también versatilidad y funcionalidad.

Una familia de lámparas que se complementa con el resto de colección outdoor de Bover, tan representativa de la personalidad mediterránea de la marca. Según Joana “Todo se resume en que las cosas sean cálidas e intemporales.” Eso es Bover y eso es Atticus.

Atticus makes any time and space more attractive.

Light and simple in its design, yet sophisticated in the possibilities it offers with its discreet personality.

“I like lamps that do not intrude,” Joana says. Atticus is always there, creating atmosphere, enveloping, but barely taking up any surface space.

Esthetics and simplicity, coupled with versatility and functionality.

A family of lamps that complements the rest of the Bover outdoor collection, representative of the brand’s Mediterranean personality. According to Joana, “It boils down to keeping things warm and timeless.” That’s Bover and that’s Atticus.

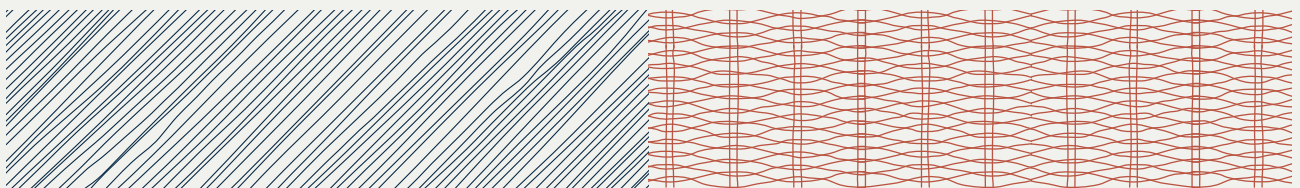

La versión baliza de Atticus, pensada para la iluminación decorativa de jardines privados, dota de cálida magia los espacios exteriores.

The Atticus bollard edition, designed for decorative lighting of private gardens, provides magical warmth to outdoor spaces.

Atticus P/01 Battery
Atticus P/02



Atticus B/01





Atticus P/01 Battery



Atticus P/01 Battery



Atticus P/02

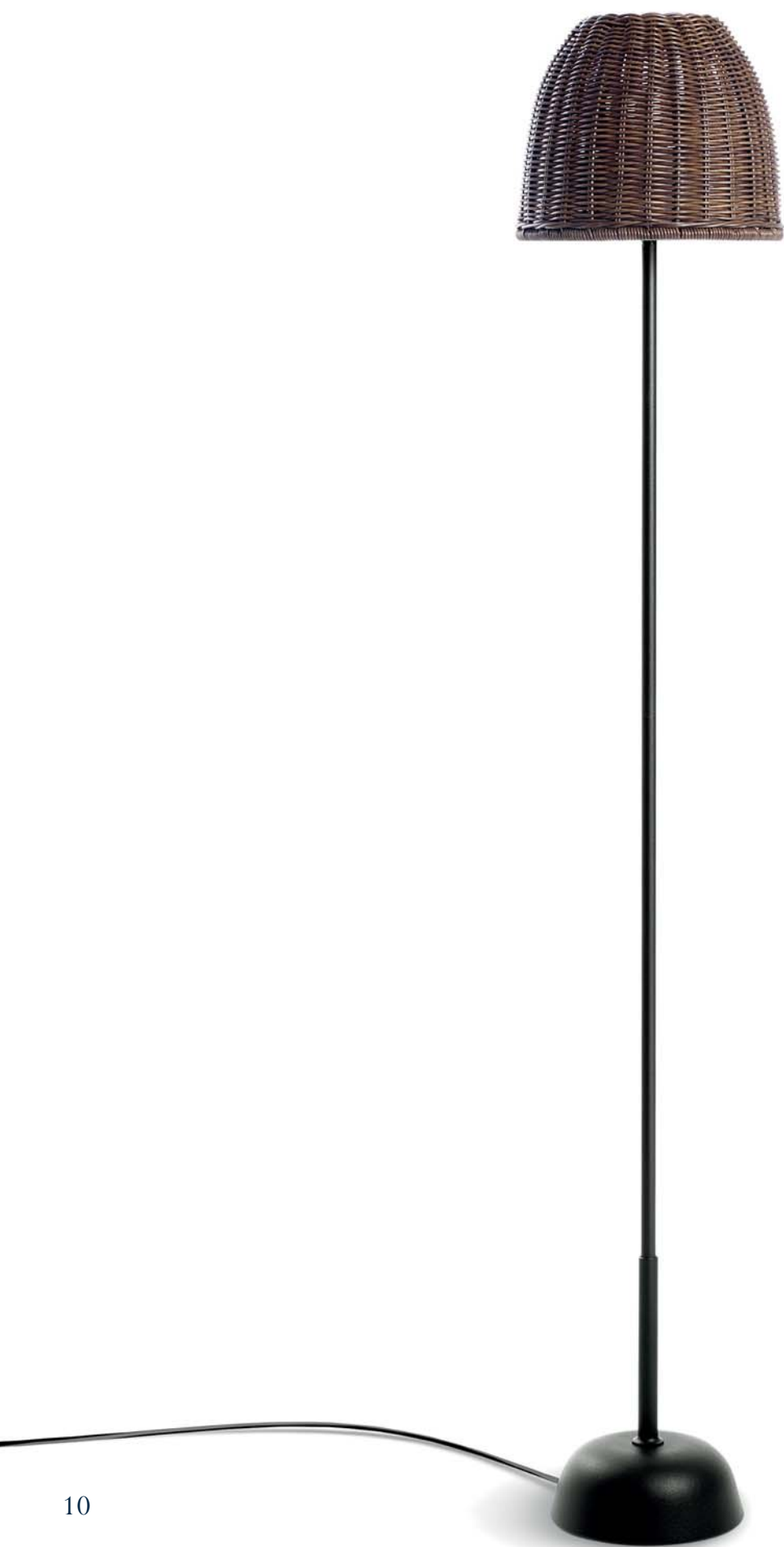

Atticus

by Joana Bover · 2017

Finishing

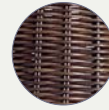

Brown

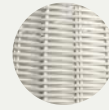

Ivory White



Light Beige

Atticus P/01 Battery

Pie exterior / Outdoor Floor



1 x 3,2 W LED | Lumens 400 lm
Valor cromático / CRI 90 | 2700K



Atticus P/02

Pie exterior / Outdoor Floor



1 x 9 W LED | Lumens 960 lm
Valor cromático / CRI 90 | 2700K



Atticus B/01- B/02

Baliza Exterior / Outdoor Bollard



Atticus B/01 Atticus B/02

1 x 9 W LED | Lumens 960 lm
Valor cromático / CRI 90 | 2700K



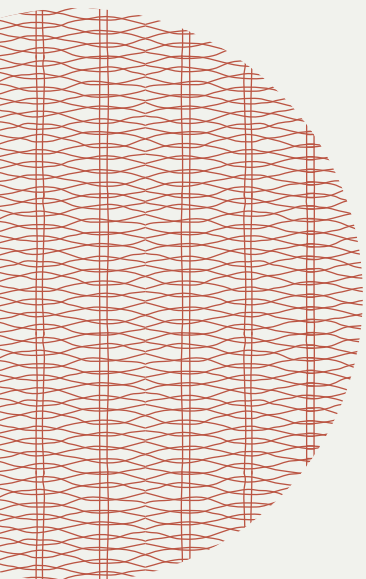
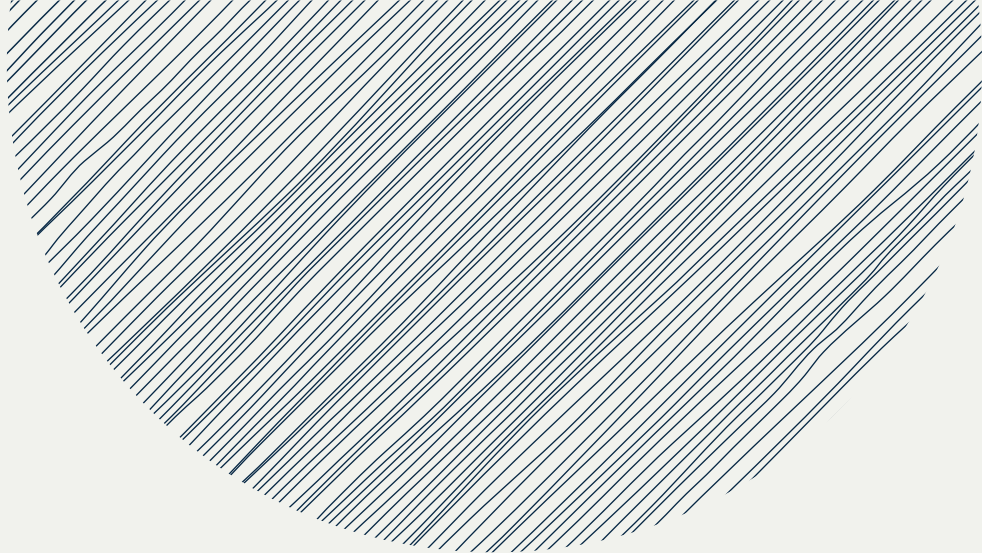

Cornet

by Alex Fernández Camps

“Las líneas de Cornet son armónicas y orgánicas; consigue mimetizarse con la naturaleza donde no existen las líneas rectas”.

“Its lines are harmonious and organic; it blends in with nature where there are no straight lines”.



Alex Fernández Camps

Cornet tiene una personalidad fuertemente arraigada en la naturaleza y alegra el espacio en el que participa.

Es una lámpara realizada en poliuretano de alta densidad con lo que se consigue un material duro y resistente perfecto para espacios públicos. El uso de Cornet es muy polifacético.

Tiene su protagonismo como baliza pero rápidamente se puede conectar con una realidad más amplia: los apliques en interior, o la versión sobremuro para los espacios intermedios. En todos los diseños, Cornet incorpora una fuente de luz LED regulable que distribuye el flujo lumínico a través de las láminas onduladas de la lámpara, creando una atmósfera natural, un poco rota y nunca dominante.

Cornet has a personality strongly rooted in nature and it brightens the space it is in.

It is a lamp made of high-density polyurethane, which is a hard and resistant material that is perfect for public spaces. The Cornet's use is very versatile.

It is mainly used as a bollard lamp but can quickly connect with a wider reality: interior wall lamps, or the post version for intermediate spaces. In all of its designs, Cornet includes a dimmable LED source that distributes light through the lamp's undulating layers, creating an atmosphere that is natural, slightly broken, but never dominant.

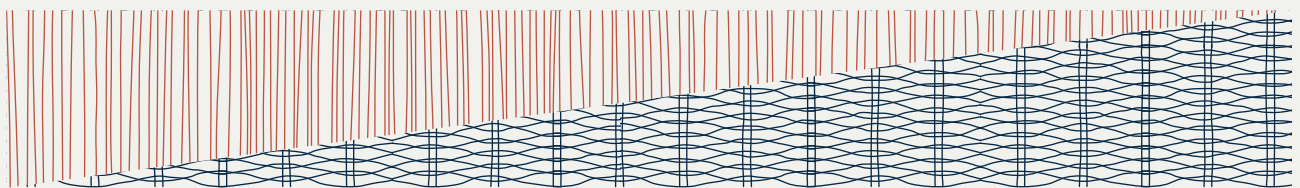

Cornet es un proyecto con alto contenido técnico pero lleno de vida.

Cornet is a highly technical project, yet full of life.

Cornet B/02



Cornet B/02





Cornet B/02





Cornet B/03



Cornet B/01 - B/02 - B/03



Cornet A/01



Cornet

by Alex Fernández Camps · 2017

Finishing



Stone Grey

Cornet A/01

Aplique Exterior / Outdoor Wall Lamp

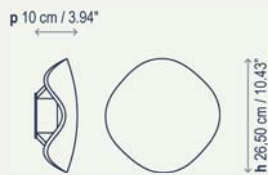

1 x 8 W LED | Lumens 860 lm
Valor cromático / CRI 90 | 2700K



Cornet B/01

Baliza Exterior / Outdoor Ballard



1 x 8 W LED | Lumens 860 lm
Valor cromático / CRI 90 | 2700K



Cornet B/02

Baliza Exterior / Outdoor Ballard



1 x 8 W LED | Lumens 860 lm
Valor cromático / CRI 90 | 2700K



Cornet B/03

Baliza Exterior / Outdoor Ballard

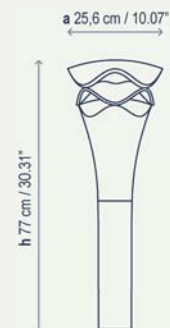

1 x 8 W LED | Lumens 860 lm
Valor cromático / CRI 90 | 2700K



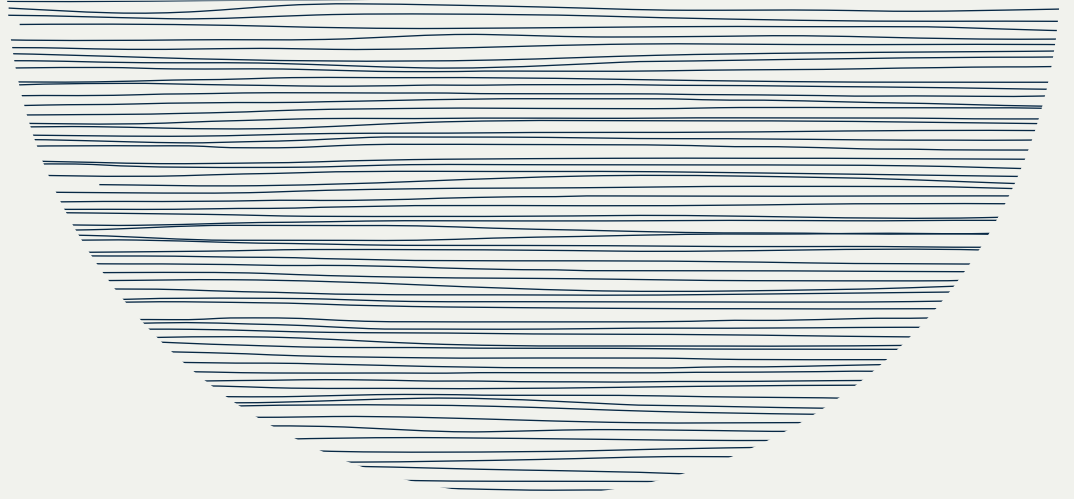

Drop

by Christophe Mathieu

“La luz al proyectarse y reflejarse en los materiales crea un juego de luces, brillos y sombras. Todo ello da riqueza al objeto”.

“When the light is projected and reflected in the materials that are found along the way, it creates a set of sparkles and shadows. All of which enriches the object”.



Christophe Mathieu

La Drop nace de conversaciones y reflexiones, de dibujos en terrazas de restaurantes y del dejarse llevar por la idea de que “una cosa lleva a la otra”. Una familia de lámparas que hablan el mismo lenguaje, pero en la que cada una tiene su propia personalidad.

Con las Drop, el objetivo estuvo claro desde el principio: hacer una lámpara de suspensión en cascada. Una de las características más destacadas de la Drop es su diversidad de tamaños. Solo en suspensión encontramos versiones de 1, de 6, de 7, de 12, de 24, de 36 y de 48 luces. Y así, a partir de esa premisa inicial, empezaron a surgir ideas de nuevas tipologías: varios apliques, dos de sobremesa, de pie con bandeja de apoyo y conexión USB e incluso una especial para bibliotecas.

The Drop is born of conversations and reflections, of drawings on terraces of restaurants and of being carried away by the idea that “one thing leads to another”. A family of lamps that speak the same language but in which each one has its own personality.

With the Drop, the goal was clear from the beginning: make a cascade pendant lamp. One of the most outstanding features of the Drop is its diversity of sizes. We find versions of 1, 6, 7, 12, 24, 36 and 48 lights only in suspension.

And so, starting from this initial premise, ideas of new typologies began to emerge: several wall lamps, two table lamps, a floor version with a support tray and USB connection, and also a specific solution for libraries.

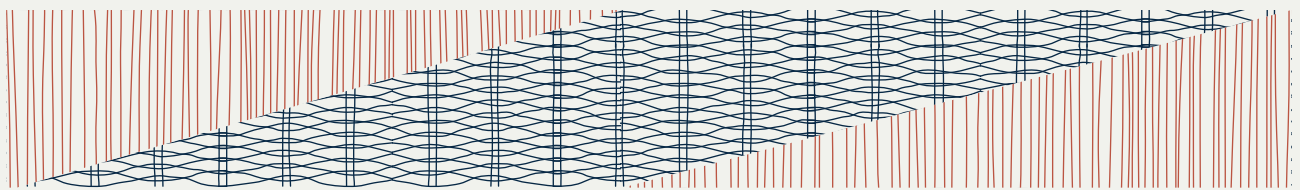

Un diseño con más de diez referencias que satisface tanto las necesidades residenciales como las del sector contract.

A design with more than ten references that satisfies both residential and contract sector needs.



Drop A/03





Drop S/01



Drop S/06



Drop S/07



Drop S/24



Drop S/48



Drop Mini
Drop T/01



Drop Biblio



Drop P/01 Tray



Drop

by Christophe Mathieu · 2017

Finishing



Drop A/01
Aplique / Wall Lamp

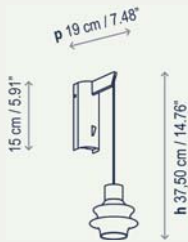

3 W LED | Lumens 345 lm
Valor cromático / CRI 90 | 2700K



Drop A/02
Aplique / Wall Lamp

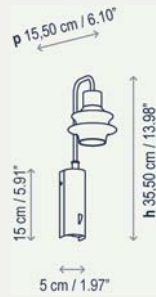

3 W LED | Lumens 345 lm
Valor cromático / CRI 90 | 2700K



Drop A/03
Aplique / Wall Lamp

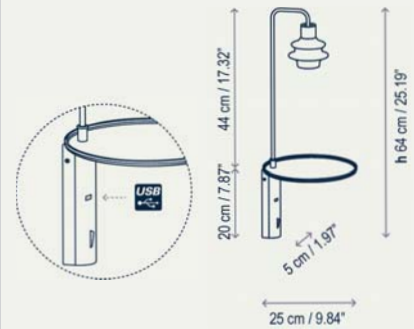

3 W LED | Lumens 345 lm
Valor cromático / CRI 90 | 2700K



Drop S/01
Suspensión / Pendant Lamp

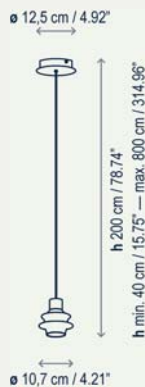

3 W LED | Lumens 345 lm
Valor cromático / CRI 90 | 2700K



Drop S/06
Suspensión / Pendant Lamp

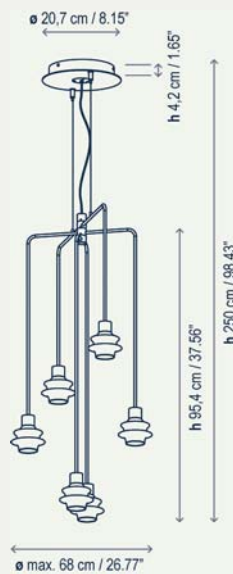

6 x 3 W = 18 W LED | Lumens 2070 lm
Valor cromático / CRI 90 | 2700K



Drop S/07
Suspensión / Pendant Lamp

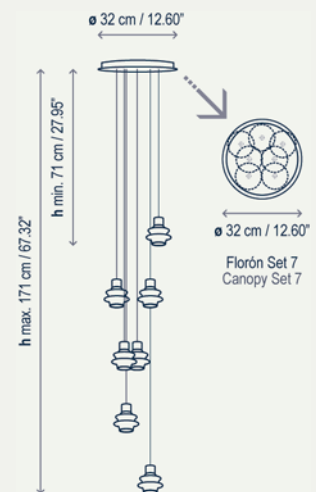

7 x 2.8 W = 19.6 W LED | Lumens 2604 lm
Valor cromático / CRI 90 | 2700K



Drop S/12
Suspensión / Pendant Lamp

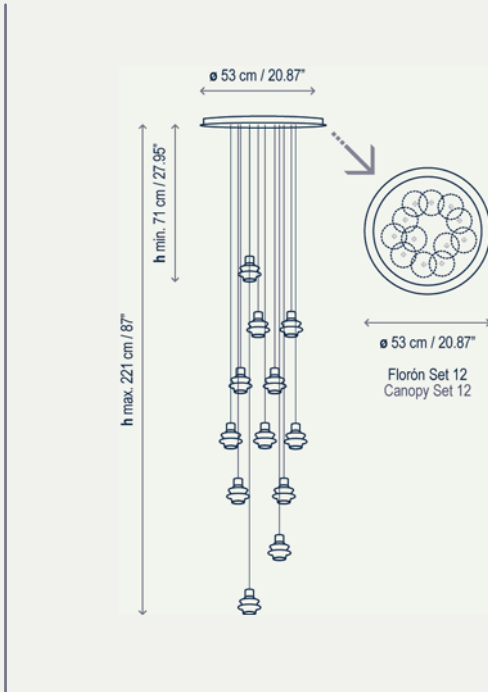

12 x 2,8 W = 33,6 W LED | Lumens 4464 lm
Valor cromático / CRI 90 | 2700K



Drop S/24
Suspensión / Pendant Lamp

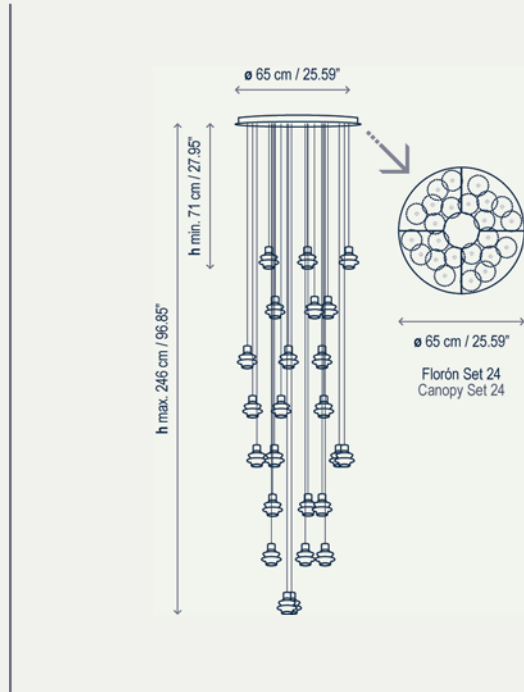

24 x 2,8 W = 67,2 W LED | Lumens 8928 lm
Valor cromático / CRI 90 | 2700K



Drop S/36
Suspensión / Pendant Lamp

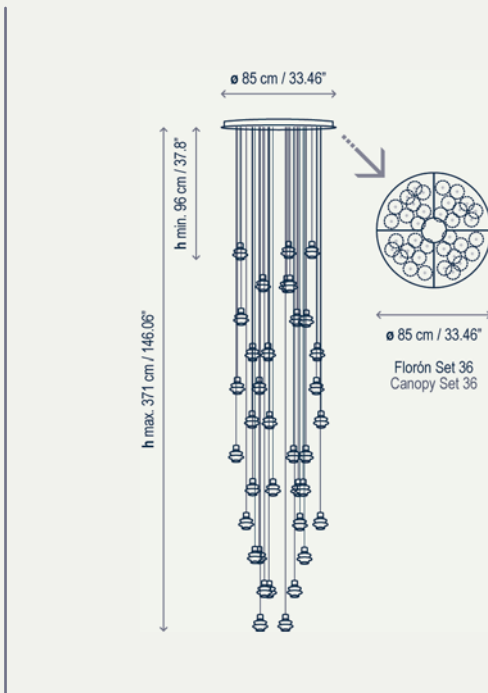

36 x 2,8 W = 100,8 W LED | Lumens 15392 lm
Valor cromático / CRI 90 | 2700K



Drop S/48
Suspensión / Pendant Lamp

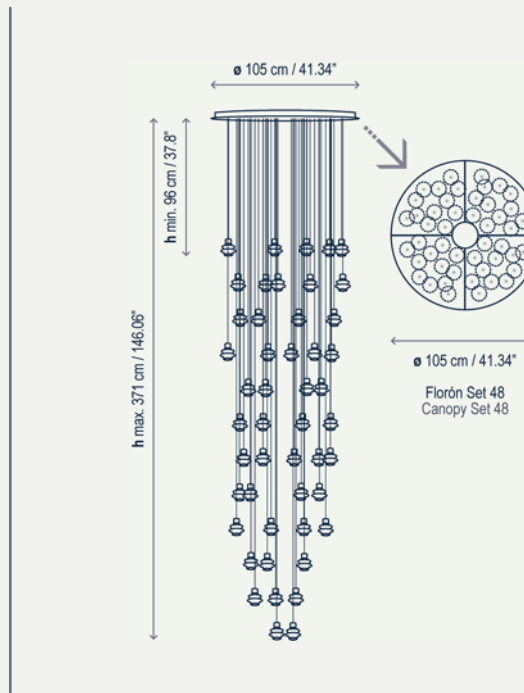

48 x 2,8 W = 134,4 W LED | Lumens 17856 lm
Valor cromático / CRI 90 | 2700K



Drop Mini
Mesa / Table Lamp



Interruptor en el cable / Through cord switch

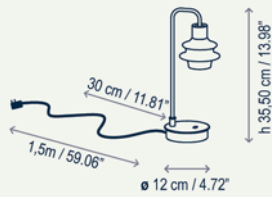

Interruptor Proxy Dimmer / Proxy Dimmer Switch

3 W LED | Lumens 345 lm
Valor cromático / CRI 90 | 2700K



Drop T/01
Mesa / Table Lamp

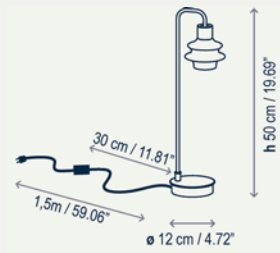

Interruptor en el cable / Through cord switch

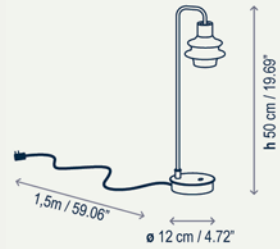

Interruptor Proxy Dimmer / Proxy Dimmer Switch

3 W LED | Lumens 345 lm
Valor cromático / CRI 90 | 2700K



Drop Biblio
Mesa / Table Lamp

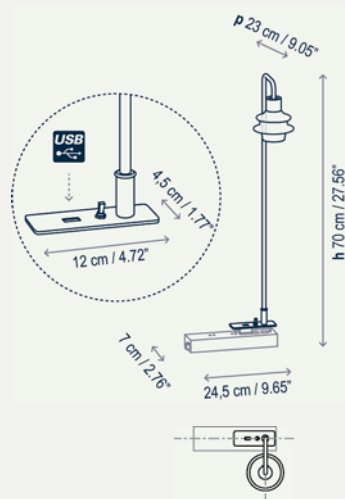

3 W LED | Lumens 345 lm
Valor cromático / CRI 90 | 2700K



Drop P/01 Tray
Pie / Floor Lamp

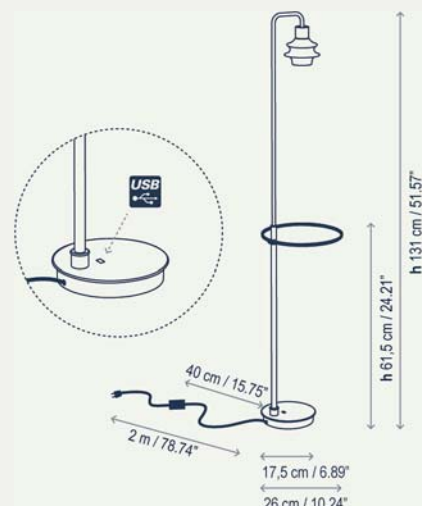

3 W LED | Lumens 345 lm
Valor cromático / CRI 90 | 2700K



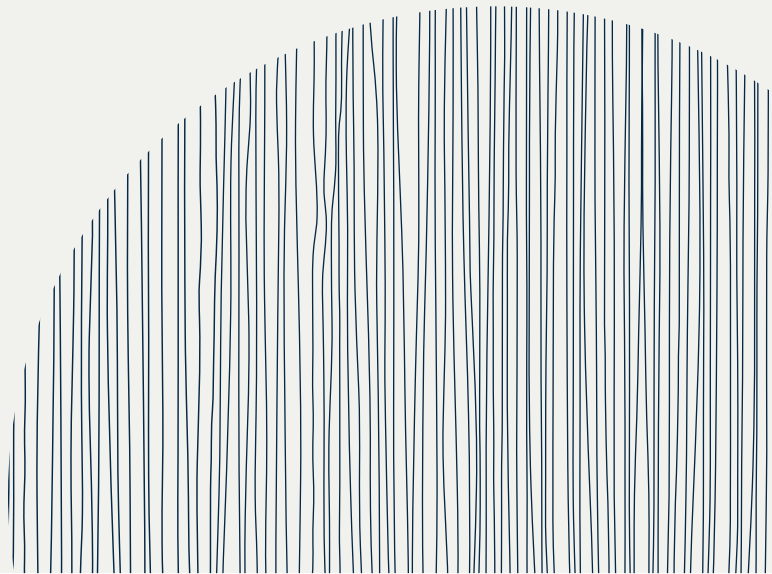

Drip

by Christophe Mathieu

“Drip te cautiva desde la distancia, su diseño te sorprende cuando te acercas y te invita a encenderla. Es ahí donde la magia alcanza su máximo esplendor”

“Drip models are captivating from a distance, their design surprises close up, inviting to light them. That is when they reach their greatest splendor”



Christophe Mathieu

Drip es llevar la diversificación de Drop a su máximo exponente. Un sistema de iluminación que no solo evoluciona en múltiples tipologías de producto, sino también en otro concepto de pantalla.

Al cambiar la pantalla, nos produce la sensación de estar junto a una lámpara totalmente nueva.

El material de la pequeña pantalla de la Drip es también vidrio borosilicato, fino y delicado. La elección del vidrio está íntimamente relacionada con la luz que crea, una luz brillante e intimista, pero que también tiene una utilidad práctica para quien se encuentra cerca.

El diseño y la funcionalidad de la Drip encajan perfectamente en proyectos residenciales y en Contract. Gracias a que puede aplicarse de múltiples maneras, funciona muy bien en hoteles, tanto en los espacios comunes como en las habitaciones.

Drip takes the diversification of the Drop to its maximum expression. A lighting system that not only evolves in multiple product types, but also in another concept of lampshades.

When we change the lampshade, we have the sensation that it is a completely new lamp.

The Drip's small lampshade is also made of borosilicate glass, fine and delicate. The choice of glass is intimately related to the light it creates, a brilliant and intimate light, that also has a practical use for those nearby.

The design and function of the Drip fits perfectly into residential projects and commercial work. Because it can be applied in many ways, it works very well in hotels, both in public spaces and in rooms.

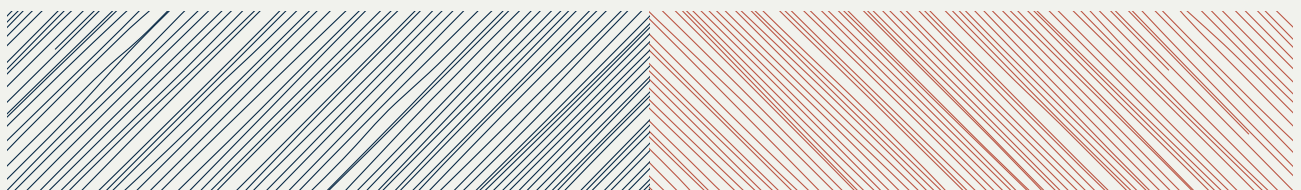

La nueva pantalla es el alma mater de la Drip; sencilla, minimalista y de líneas rectas.

The new lampshade is Drip's alma mater: simple, minimalist and with straight lines.

Drip A/01



Drip S/01



Drip Mini



ROBERT LONGO — CHARCOAL

SOMETHING ABOUT YOUR BRAIN

Be prepared | Wrocław - welcome in Polish diamonds

Drip P/01 Tray



Drip

by Christophe Mathieu · 2017

Finishing



Drip A/01
Aplique / Wall Lamp

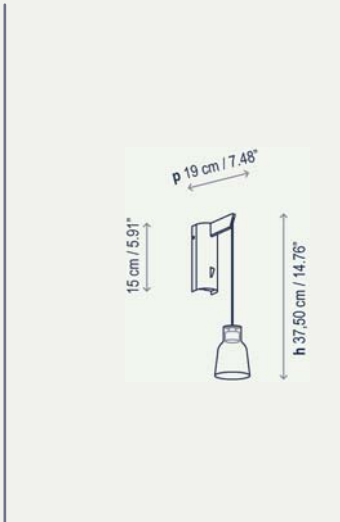

3 W LED | Lumens 345 lm
Valor cromático / CRI 90 | 2700K



Drip A/02
Aplique / Wall Lamp

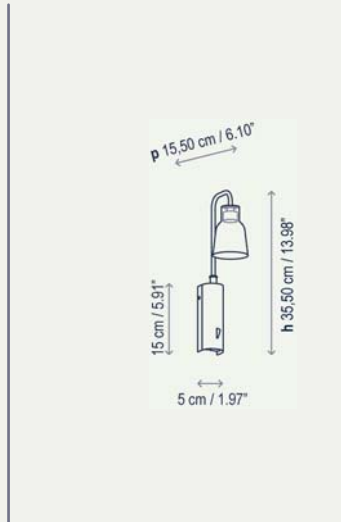

3 W LED | Lumens 345 lm
Valor cromático / CRI 90 | 2700K



Drip A/03
Aplique / Wall Lamp



3 W LED | Lumens 345 lm
Valor cromático / CRI 90 | 2700K



Drip S/01
Suspensión / Pendant Lamp

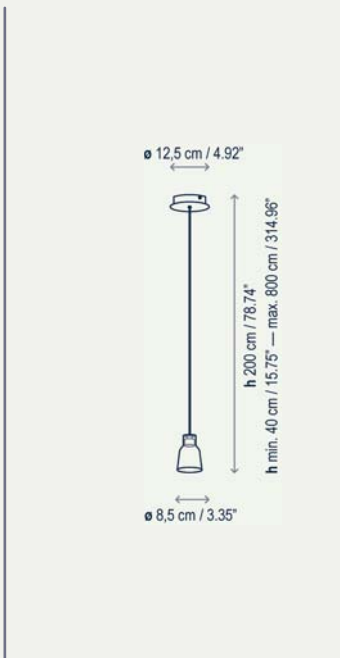

3 W LED | Lumens 345 lm
Valor cromático / CRI 90 | 2700K



Drip S/06
Suspensión / Pendant Lamp

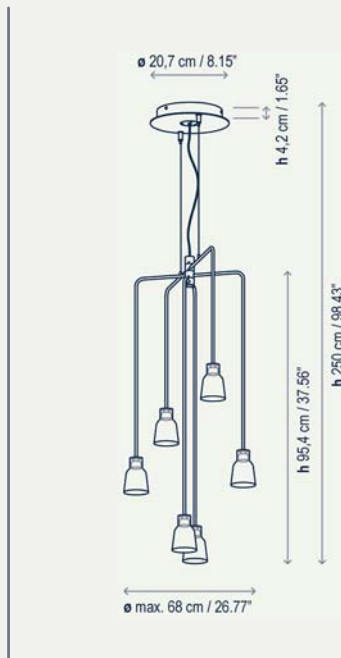

6 x 3 W = 18 W LED | Lumens 2070 lm
Valor cromático / CRI 90 | 2700K



Drip S/07
Suspensión / Pendant Lamp

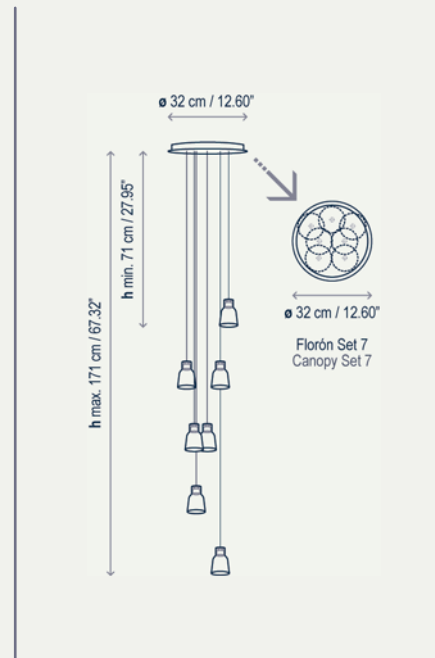

7 x 2.8 W = 19.6 W LED | Lumens 2604 lm
Valor cromático / CRI 90 | 2700K



Drip S/12
Suspensión / Pendant Lamp

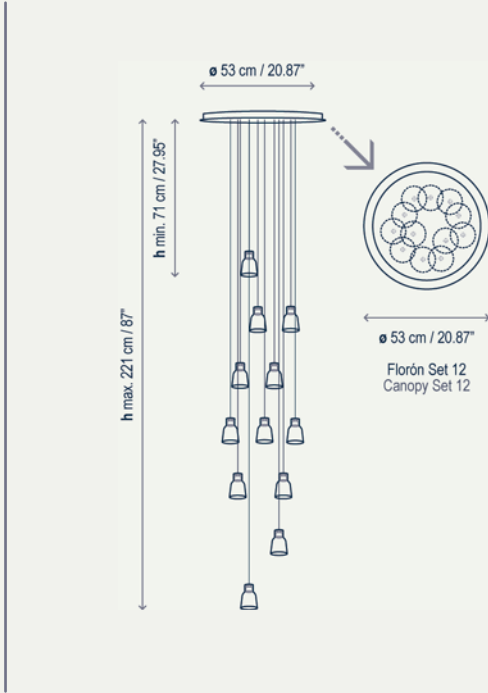

12 x 2,8 W = 33,6 W LED | Lumens 4464 lm
Valor cromático / CRI 90 | 2700K



Drip S/24
Suspensión / Pendant Lamp

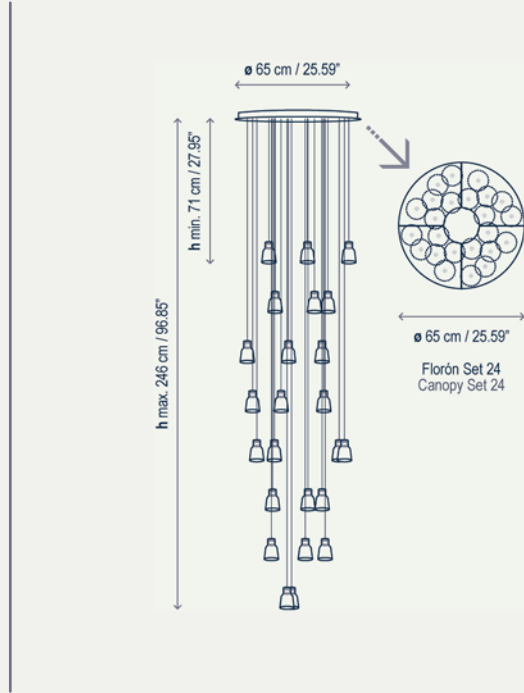

24 x 2,8 W = 67,2 W LED | Lumens 8928 lm
Valor cromático / CRI 90 | 2700K



Drip S/36
Suspensión / Pendant Lamp

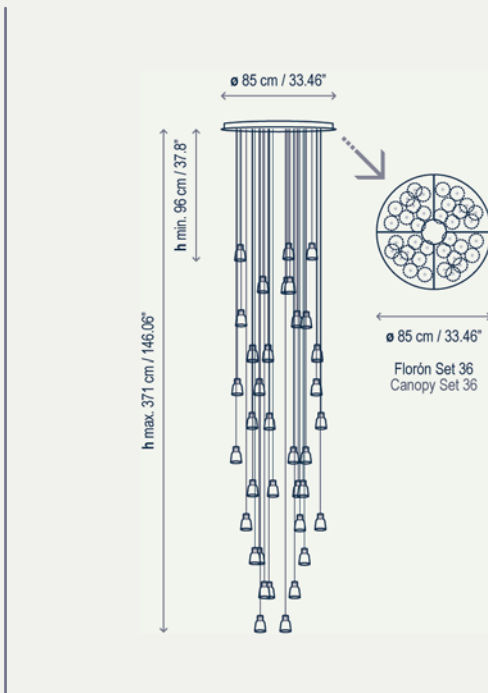

36 x 2,8 W = 100,8 W LED | Lumens 15392 lm
Valor cromático / CRI 90 | 2700K



Drip S/48
Suspensión / Pendant Lamp

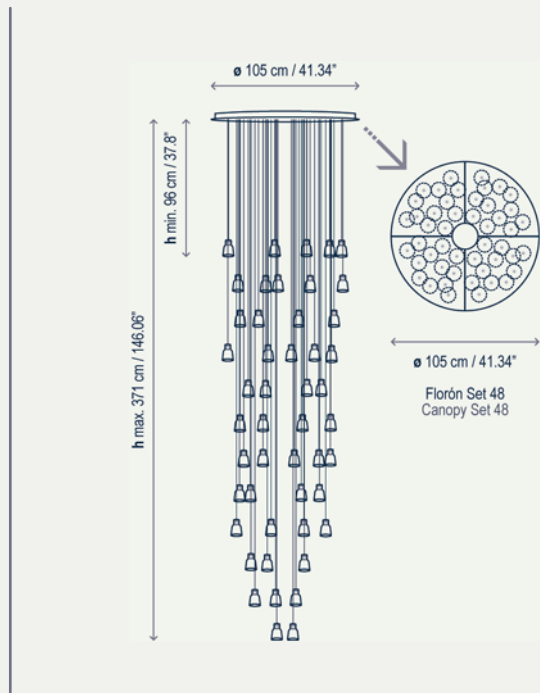

48 x 2,8 W = 134,4 W LED | Lumens 17856 lm
Valor cromático / CRI 90 | 2700K



Drip Mini
Mesa / Table Lamp



Interruptor en el cable / Through cord switch



Interruptor Proxy Dimmer / Proxy Dimmer Switch

3 W LED | Lumens 345 lm
Valor cromático / CRI 90 | 2700K



Drip T/01
Mesa / Table Lamp

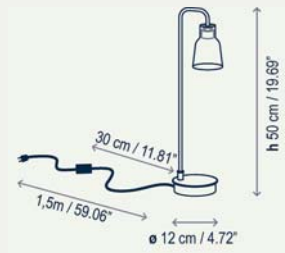

Interruptor en el cable / Through cord switch

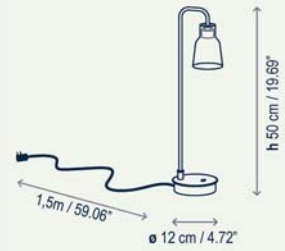

Interruptor Proxy Dimmer / Proxy Dimmer Switch

3 W LED | Lumens 345 lm
Valor cromático / CRI 90 | 2700K



Drip Biblio
Mesa / Table Lamp

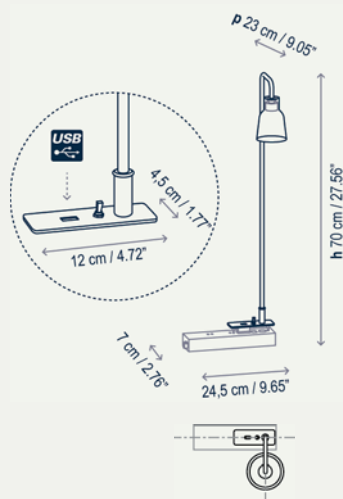

3 W LED | Lumens 345 lm
Valor cromático / CRI 90 | 2700K



Drip P/01 Tray
Pie / Floor Lamp

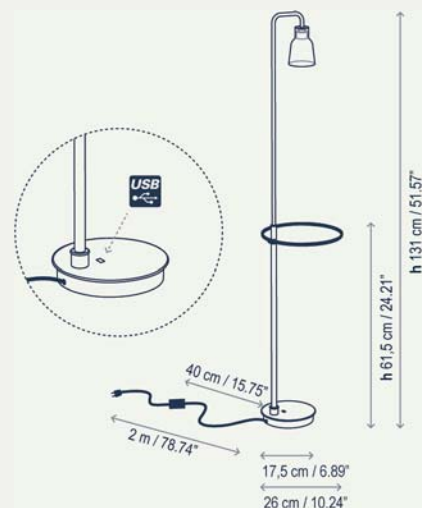

3 W LED | Lumens 345 lm
Valor cromático / CRI 90 | 2700K



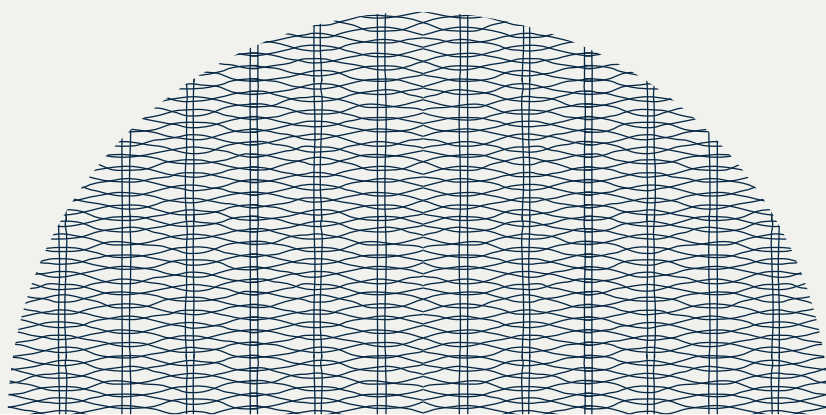

Marietta Outdoor

by Joana Bover

“La Marietta original es claramente una luminaria de interior pero he querido abrirla las puertas y llevarla al exterior”.

“The original Marietta is clearly an indoor light but I wanted to adapt it for outdoor settings.”



Joana Bover

Marietta Outdoor | by Joana Bover

Una lámpara pensada para terrazas, parasoles y pérgolas; y también para cocinas, bares y restaurantes. Un todoterreno perfecto para todos estos espacios: resistente, fácil de limpiar y muy polivalente. Esta polivalencia tiene que ver con la atemporalidad que busca siempre Joana en sus diseños. Piezas que pueden estar al lado de piezas clásicas pero también conviviendo con piezas contemporáneas, integrándose de manera natural en la vida de las personas.

La Marietta Outdoor es por muchas razones un ejemplo de diseño cocinado lentamente donde tiene un papel relevante el no conformismo y la convicción de Joana por llegar al mejor producto final posible.

It is a lamp designed for terraces, parasols and pergolas; and also for kitchens, bars and restaurants. It is a perfect go-to for all these spaces: resistant, easy to clean and very versatile. This versatility has to do with the timelessness that Joana is always looking for in her designs. Her works can stand next to classical pieces and with contemporary ones. This ensures they can be incorporated naturally into people's lives.

The Marietta Outdoor is, for many reasons, an example of 'slow-cooked' design where non-conformity and Joana's conviction play important roles in creating the best possible final product.

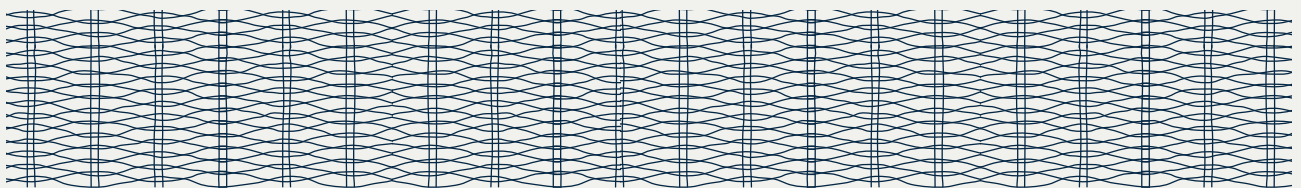

Cada pequeño detalle de Marietta Outdoor está pensado mil veces. Un trabajo de precisión que se hace siempre en Bover con cada lámpara.

Every little detail of Marietta Outdoor was thought about a thousand times. Bover takes this precise approach with every lamp.

Marietta Outdoor





Marietta Outdoor





Marietta Outdoor

by Joana Bover · 2017

Marietta Outdoor

Suspensión Exterior / Outdoor Pendant Lamp



1 x 8 W LED | Lumens 664 lm
Valor cromático / CRI 80 | 2700K



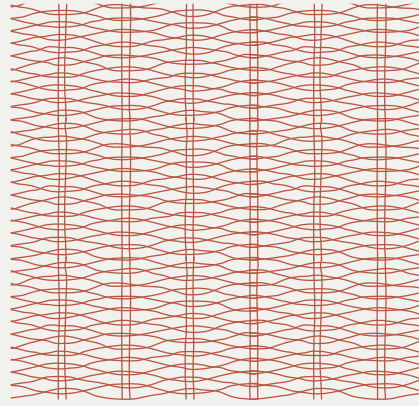
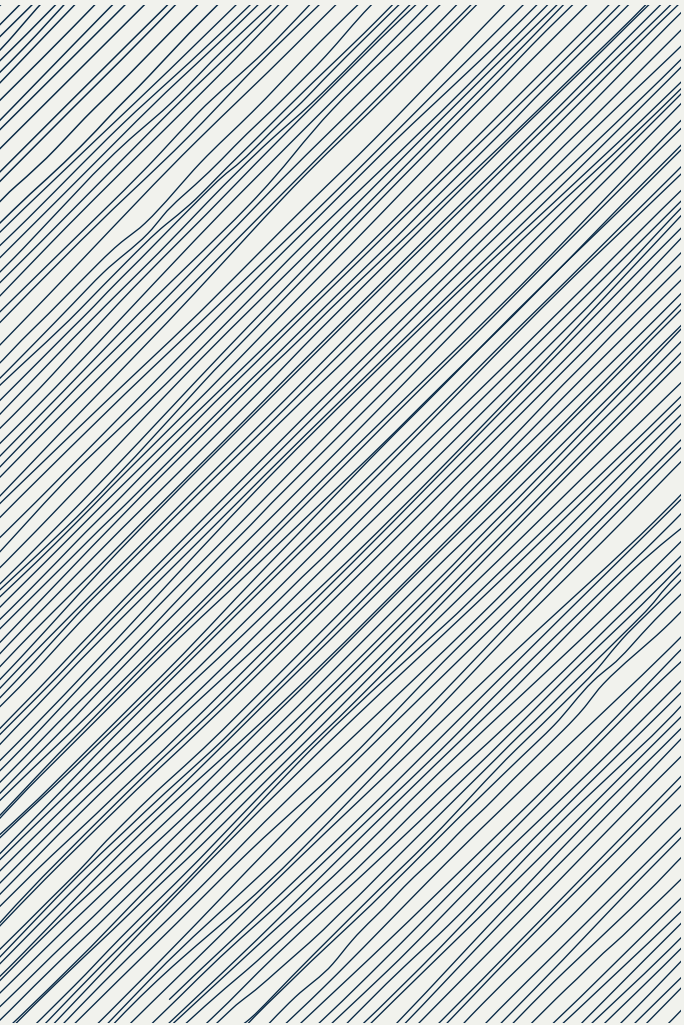

Moai

by Gonzalo Milà

“Hemos conseguido que la lámpara se ilumine completamente a sí misma, a través de su juego de formas. El resultado es una luz suave y cálida en contraste con el hormigón”.

"We have managed to get the lamp to illuminate itself completely through its play of shapes. The result is a soft, warm light in contrast to the concrete".



Gonzalo Milà

Moai es de hormigón reforzado, lo cual permite ubicarla perfectamente tanto en espacios residenciales como públicos. Pero su creatividad no reside tanto en la elección del material, sino en la forma que Gonzalo le ha dado y en cómo la luz juega y se compenetra con esa forma. Por detrás, la lámpara baliza muestra un plano recto y duro, mientras que por delante las líneas se suavizan.

Moai cuenta con una fuente LED dimable que proyecta luz hacia abajo. Al LED se le ha añadido una óptica que hace las funciones de lupa; generando a su vez un cono de luz en sentido lateral. Y ahí está la interesante sorpresa: toda la parte cóncava de Moai aparece iluminada sin que ningún rincón quede a oscuras. “Las balizas de exterior dan luz al suelo o sobre si misma pero sin jugar con la forma”, explica Gonzalo.

Moai is made from reinforced concrete, allowing this to be suited for commercial projects as well as residential. But his creativity lies not so much in the choice of material, but rather in the form that Gonzalo gives it and how the light plays with and penetrates that form. From behind, the lamp seems straight and hard, while front lines are softened.

Moai comes with a dimmable LED source that projects light downward. An optical lens has been added to the LED, which works as a magnifying glass; generating in turn a laterally projecting cone of light. And there is the interesting surprise: all of Moai's concavity appears illuminated without leaving any corner in the dark. “The external bollards illuminate the ground or itself but without playing with the shape”, explains Gonzalo.

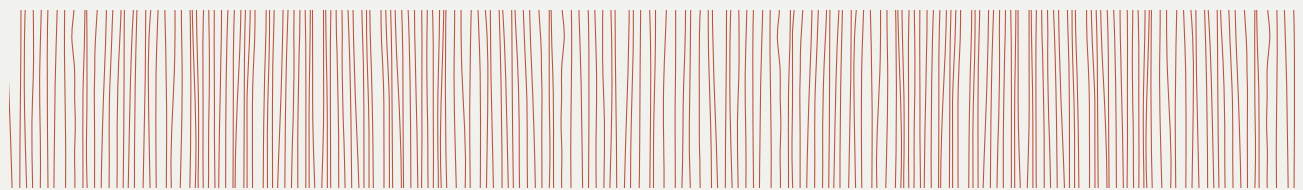

Moai es una lámpara de exterior donde hormigón, forma y luz trabajan juntas para dar protagonismo absoluto a esta sorprendente y novedosa unión.

Moai is an outdoor lamp where concrete, shape and light work together to give absolute prominence to this surprising and novel union.

Moai B /01



Moai B/02





Moai B/01 - B/02



Moai

by Gonzalo Milà · 2017

Finishing

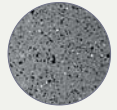

Grey
Concrete

Moai B/01

Baliza Exterior / Outdoor Bollard



1 x 6,5 W LED | Lumens 850 lm
Valor cromático / CRI 90 | 2700K



Moai B/02

Baliza Exterior / Outdoor Bollard

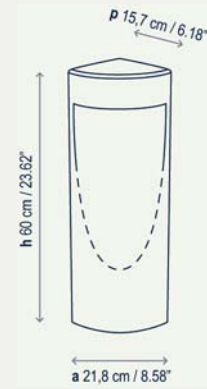

1 x 6,5 W LED | Lumens 850 lm
Valor cromático / CRI 90 | 2700K



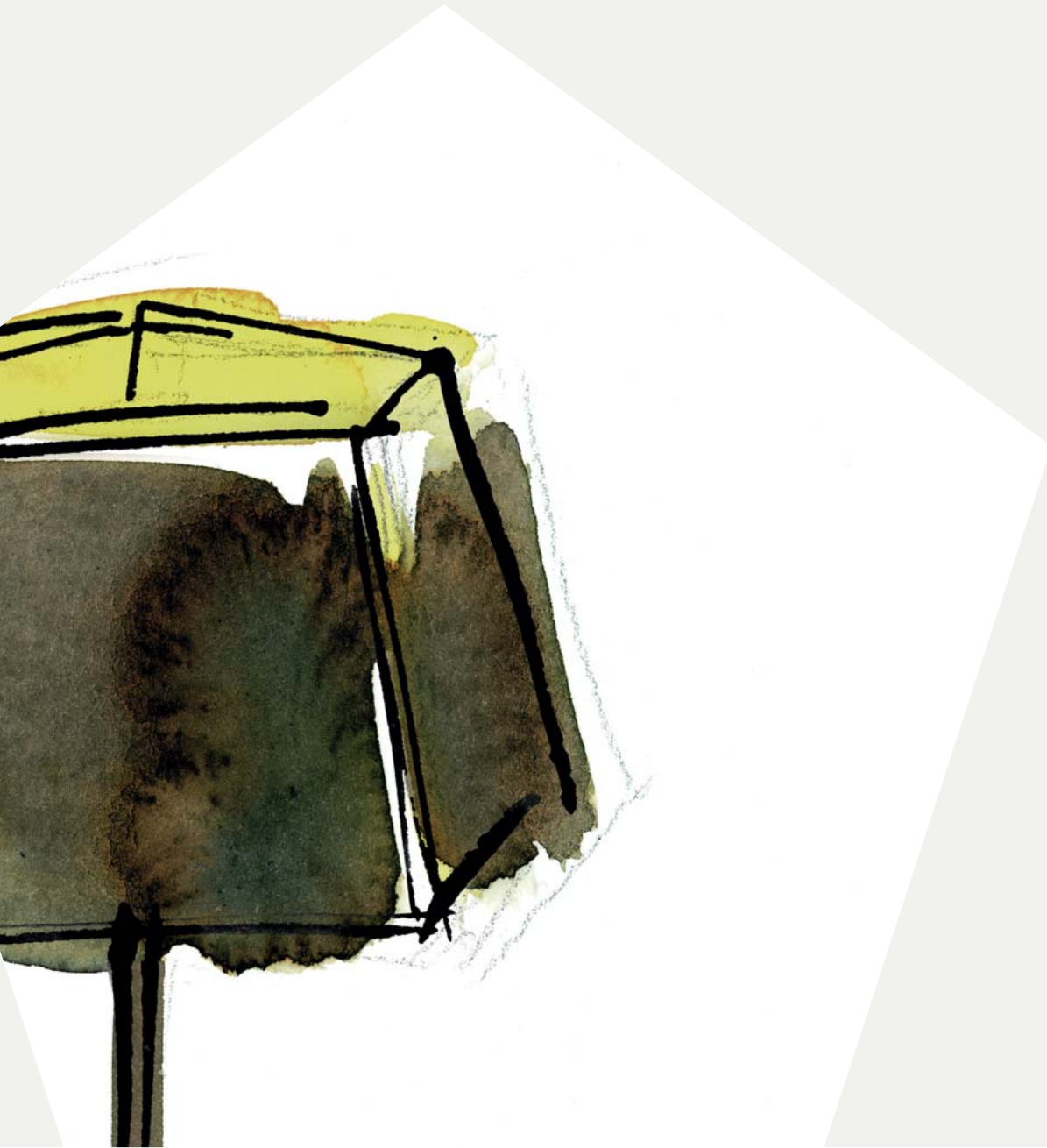
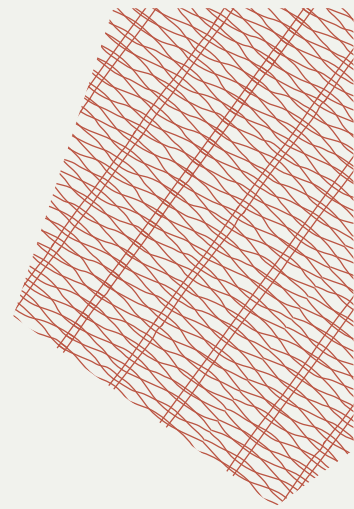
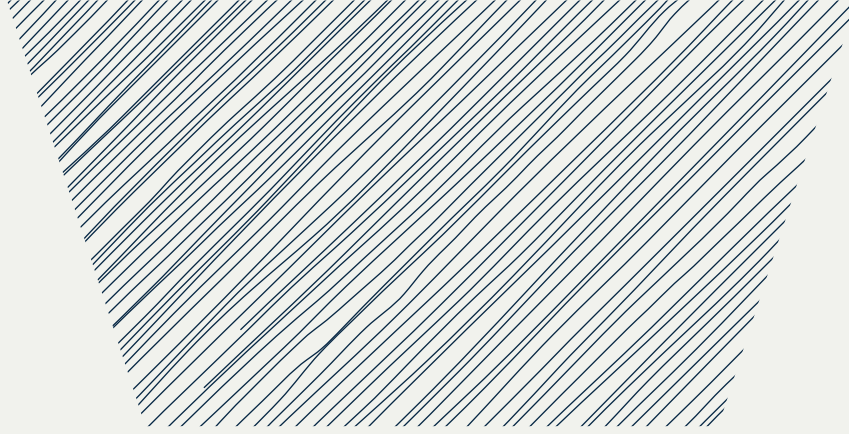

Penta

by Gonzalo Milà / Juan Carlos Ines

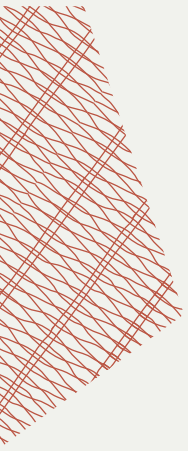

“Queríamos que se pudieran tener conversaciones alrededor de una mesa viendo las caras de las personas con las que hablas”.

“We wanted to have conversations around a table looking at the faces of the people that you’re talking to”.



Gonzalo Milà



Juan Carlos Ines

En 1996, Gonzalo Milà y Juan Carlos Ines diseñaron una lámpara de suspensión hecha de aluminio. Pero en aquel momento su idea quedó en un prototipo.

El momento de ver la luz le llegó por fin a Penta, y un cambio muy importante para conseguirlo fue sustituir la plancha plegada inicial por la técnica de estampación.

Se han escogido para Penta tres acabados: latón, aluminio y cobre; respetando su color en el interior de la lámpara y aplicando un proceso de oxidación en el exterior de la misma

“La premisa era hacer una lámpara interior de sobremesa en la que se pudiera tener una superficie iluminada pero que no deslumbrara”. Hay que escoger un rincón y dejar que Penta cree su cálida atmósfera, bien como luz de ambiente o iluminando un espacio gracias al dimmer que incorpora.

In 1996, Gonzalo Milà and Juan Carlos Ines designed a lamp made of aluminium. But at that time his idea was a prototype.

The moment to launch Penta finally arrived, and a very important change to make it happen was to replace the initial folded plate with the stamping technique.

Three finishes have been chosen for Penta: brass, aluminum and copper; respecting the lamp's interior color and applying an oxidation process to the outside of the lamp.

“The premise was to make an interior table lamp in which you could have a lightened surface that doesn't dazzle”. Choose a corner and let Penta create its warm atmosphere, either illuminating a space or as mood lighting thanks to the incorporated dimmer.

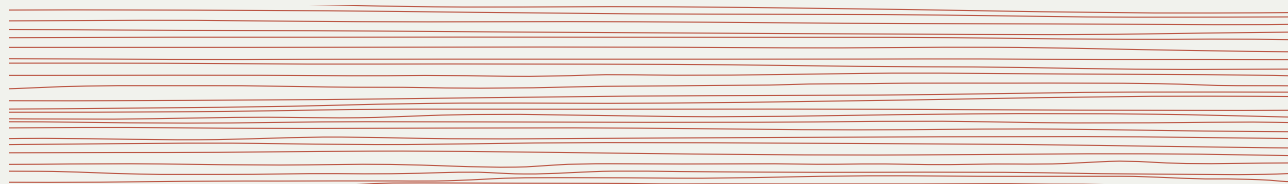

Penta no solo encuentra fácilmente su lugar en el hogar sino que también se adapta perfectamente al ambiente de un hotel o a cualquier tipo de proyecto dentro del sector Contract.

Penta not only easily finds its place in the home but also perfectly adapts to the environment of a hotel or to any type of project within the Contract sector.

Penta S



Penta S





Penta S



Penta S

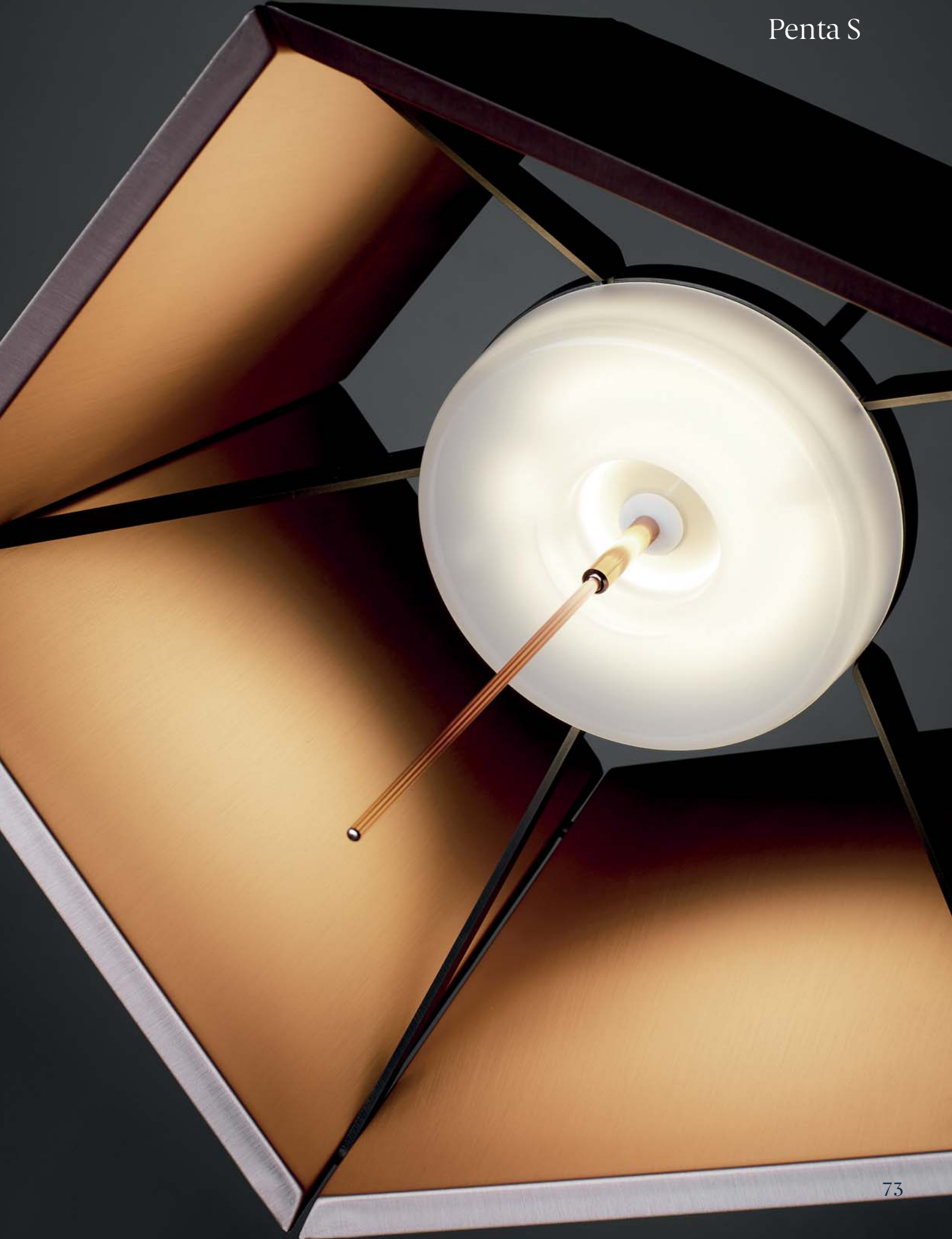





Penta P



Penta

by Gonzalo Milà / Juan Carlos Ines · 2017

Finishing



Penta S
Suspensión / Pendant Lamp



8,2 W LED | Lumens 799 lm
Valor cromático / CRI 90 | 2700K



Penta T
Mesa / Table Lamp

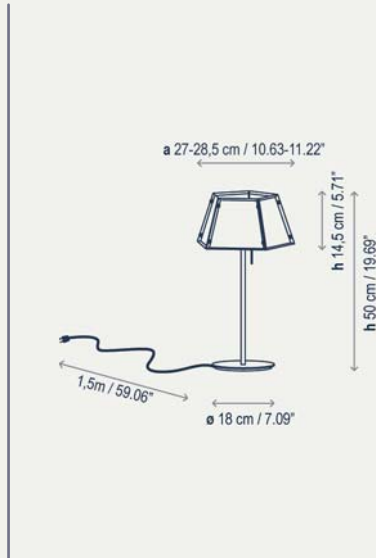

8,2 W LED | Lumens 799 lm
Valor cromático / CRI 90 | 2700K



Penta P
Pie / Floor Lamp



8,2 W LED | Lumens 799 lm
Valor cromático / CRI 90 | 2700K



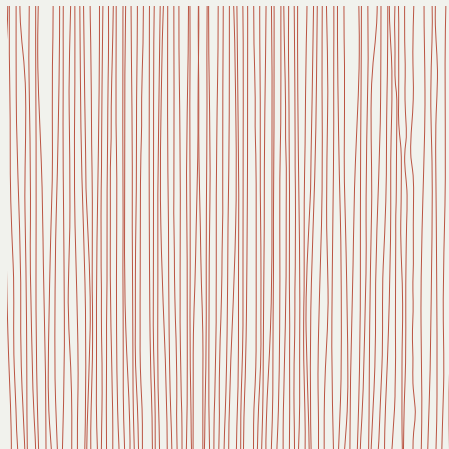
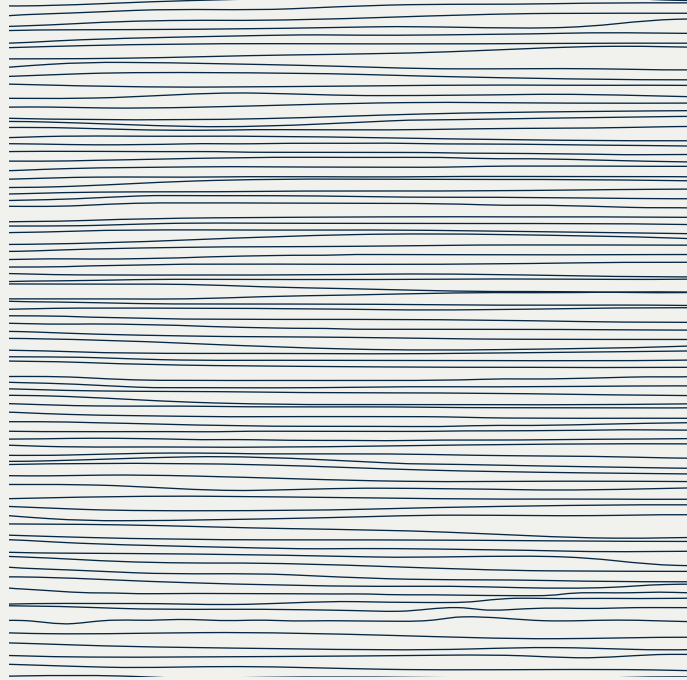

Tibeta

by Christophe Mathieu

“Intento darle importancia también a la luz que recibe la lámpara. La luz al chocar contra su superficie crea un objeto mucho más rico”.

“I try to give importance also to the light that falls on the lamp. The light hitting its surface creates a much richer object”.



Christophe Mathieu

Tibeta | *by Christophe Mathieu*

Tibeta es una familia de luminarias de suspensión. Realizadas a partir de un cuerpo de aluminio torneado. Está formada por tres volúmenes de distintas dimensiones y formas, que pueden ser utilizados tanto individualmente como en conjuntos de 3 unidades o más, según cuales sean las necesidades del usuario. Los tres objetos son de aluminio recubierto por un baño electrolítico.

Su parte interior alberga un pequeño módulo de led proporcionando una luz directa inferior.

Tibeta is a family of pendant lights made of a spun aluminum body.

It is available in three different sizes and shapes which can be used either individually or in groups of three or more units according to client's needs.

Tibeta includes an LED module inside, which provides direct bottom light.

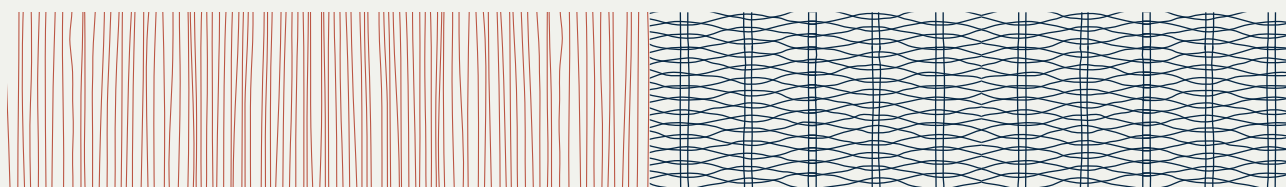

Presentamos el nuevo acabado, latón envejecido, que completa la colección junto con los acabados cromo negro y cobre.

The new finishing, antique brass, is a neutral and elegant color that perfectly completes the collection available also in black chrome and copper.

Tibeta



Tibeta 01



Tibeta

by Christophe Mathieu

Finishing



Black
Chrome

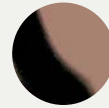

Brilliant
copper

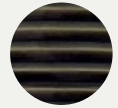

Antique
brass

Tibeta 01

Suspensión / Pendant Lamp

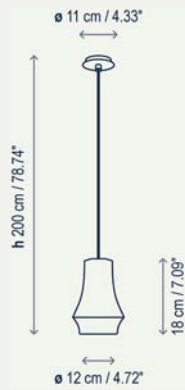

8,7 W LED | Lumens 610 lm
Valor cromático / CRI >80 | 2900-3200K



Tibeta 02

Suspensión / Pendant Lamp

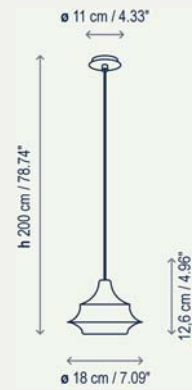

8,7 W LED | Lumens 610 lm
Valor cromático / CRI >80 | 2900-3200K



Tibeta 03

Suspensión / Pendant Lamp



13 W LED | Lumens 935 lm
Valor cromático / CRI >80 | 2900-3200K



Tibeta Set 3

Suspensión / Pendant Lamp

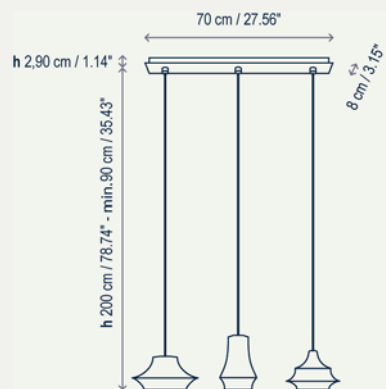

30,4 W LED | Lumens 2155 lm
Valor cromático / CRI >80 | 2900-3200K



“Creamos
objetos que
reciben y
ofrecen luz”



*“We create
objects that
receive and
provide light”*

Joana Bover

bover
barcelona lights

Av. Catalunya, 173 T + 34 938 713 152
Polígon Ind. Sud + 938 462 089
08440 Cardedeu info@bover.es
Barcelona, Spain www.bover.es

BOVER USA INC
1231 Collier Road Suite C
Atlanta, GA 30318
United States

T + 1 404 924 2342
info@boverusa.com
www.boverusa.com

